

**Beladen**

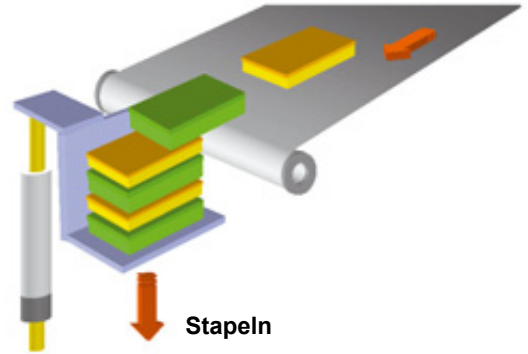

**Stapeln**

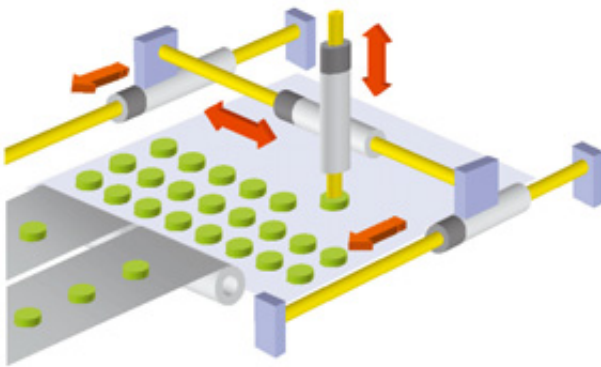

**Palettieren**

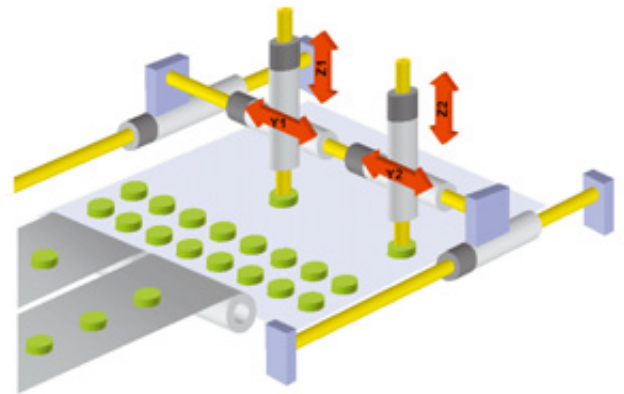

**Palettieren**

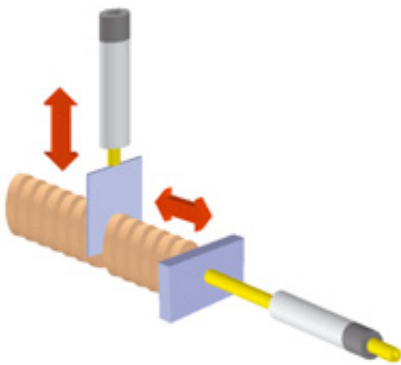

**Schneiden**

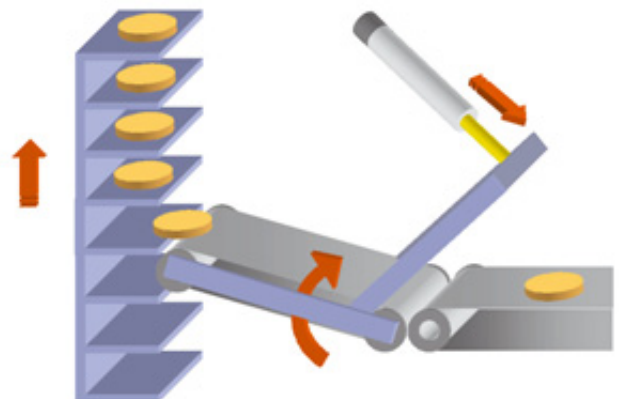

**Beladen**

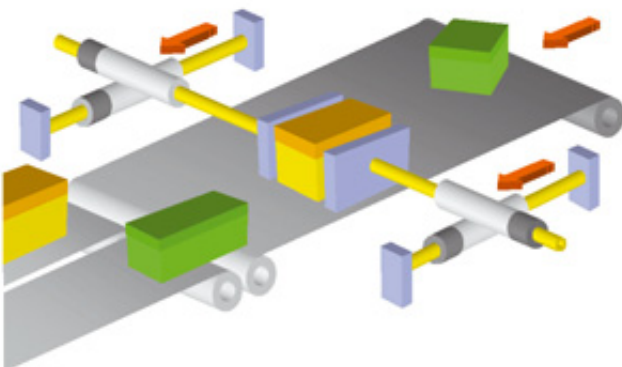

**Ausrichten**

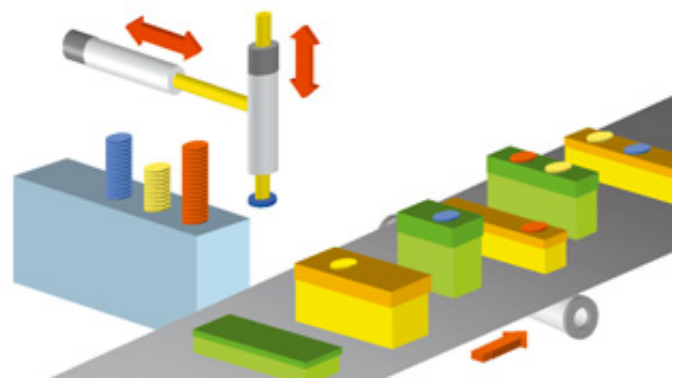

**Etikettieren**



2-Achs Montage Modul

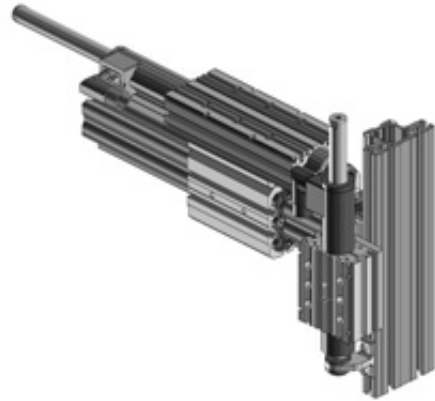

2-Achs Pick and Place

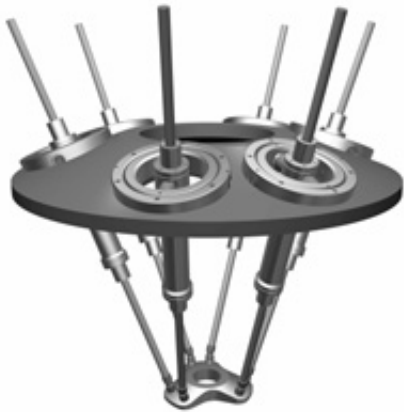

Hexapod Parallelkinematik

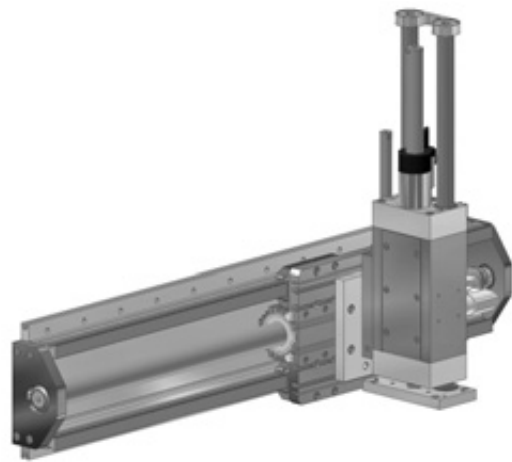

Montagemodul



4-Achs Palettierroboter

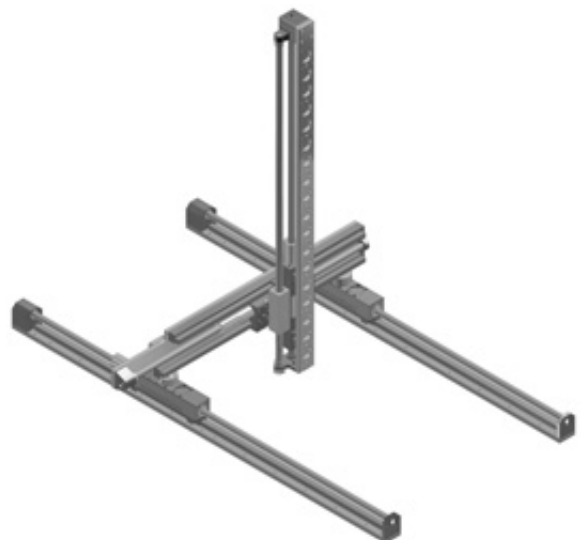

4-Achs Be- und Entladestation