

**P01-23x80/10x50 60**

**P01-23x80/30x90 62**

**P01-23x80/50x110 64**

**P01-23x80/80x140 66**

**P01-23x80/150x210 68**

**P01-23x80/210x270 70**

**P01-23x80/280x340 72**

**P01-23x80/340x400 74**

**P01-23x80/440x500 76**

**P01-23x80/620x680 78**

**P01-23x80/710x770 80**

**Maximaler Hub: 50mm**  
**Spitzenkraft: 39N**

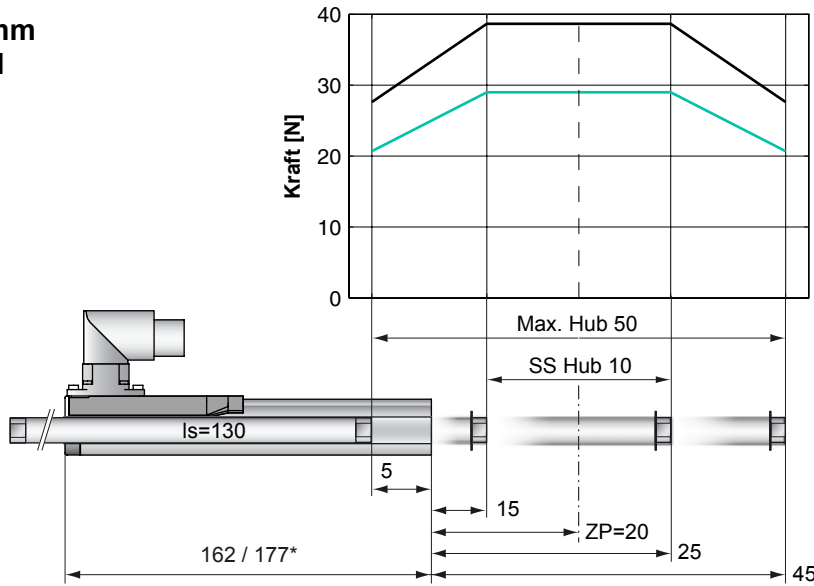

**Standard Wicklung:**  
 — E1100, 72VDC & E1001, 72VDC  
 — E100, 48VDC

Abmessungen mm  
 \*Kabel Typ

## Motor Spezifikation

P01-		Stecker Typ	Kabel Typ
		23x80/10x50-R	23x80/10x50 23x80/10x50-R20
Maximaler Hub	mm (in)	50 (1.97)	50 (1.97)
Kurzhubbereich SS	mm (in)	10 (0.39)	10 (0.39)
Spitzenkraft E1100 / E1001	N (lbf)	39 (8.7)	39 (8.7)
Spitzenkraft E100	N (lbf)	29 (6.5)	29 (6.5)
Kont. Kraft	N (lbf)	8 (1.7)	8 (1.7)
Kont. Kraft mit Lüfter	N (lbf)	14 (3.2)	14 (3.2)
Randkraft	%	71	71
Kraftkonstante	N/A (lbf/A)	9.7 (2.17)	9.7 (2.17)
Max. Strom @ 72VDC	A	4.0	4.0
Max. Strom @ 48VDC	A	3.8	3.8
Max. Gesch. @ 72VDC	m/s (in/s)	6.9 (270)	6.9 (270)
Max. Gesch. @ 48VDC	m/s (in/s)	4.6 (180)	4.6 (180)
Phasenwider. 25/80 °C	Ohm	10.3/12.5	10.3/12.5
Phaseninduktivität	mH	1.4	1.4
Therm. Widerstand	°K/W	7.0	7.0
Therm. Zeitkonstante	sec	1600	1600
Statordurchmesser	mm (in)	23 (0.91)	23 (0.91)
Statorlänge	mm (in)	162 (6.38)	177 (6.97)
Stormasse	g (lb)	265 (0.58)	265 (0.58)
Läuferdurchmesser	mm (in)	12 (0.47)	12 (0.47)
Läuferlänge	mm (in)	130 (5.12)	130 (5.12)
Läufermasse	g (lb)	89 (0.20)	89 (0.20)
Wiederholgenauigkeit	mm (in)	±0.05 (±0.0020)	±0.05 (±0.0020)
Linearität	%	±0.70	±0.70
Wiederholgenauigk. ES	mm (in)	±0.01 (±0.0004)	±0.01 (±0.0004)
Linearität ES	mm (in)	±0.01 (±0.0004)	±0.01 (±0.0004)

## Hub-Zeit Diagramm

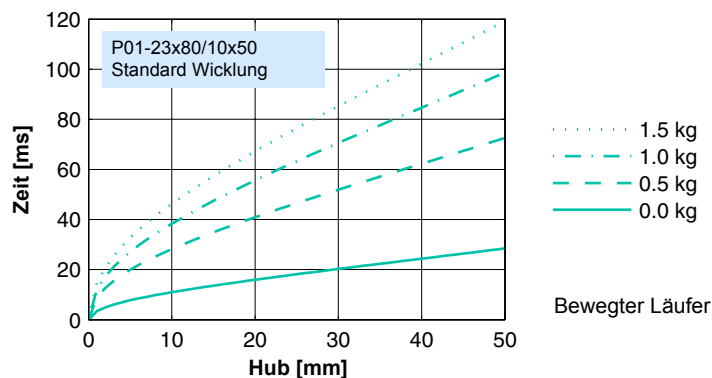

## Stecker Typ

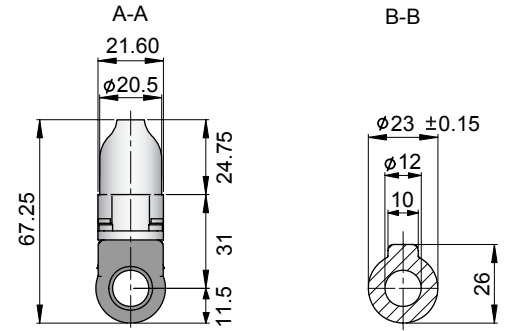
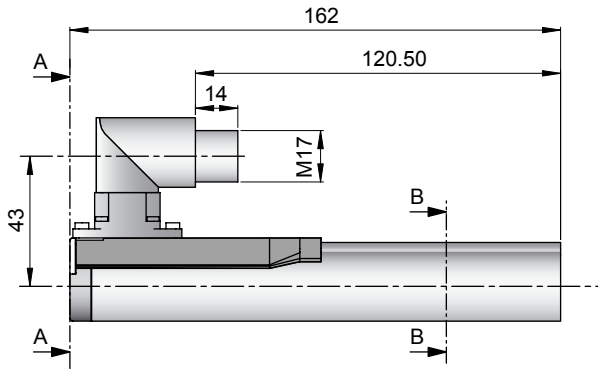

Linearmotor		Stator			Läufer	
Typ	Art. Nr.	Typ	Art. Nr.	Typ	Art. Nr.	
P01-23x80/10x50-R	-->	PS01-23x80-R	0150-1233	&	PL01-12x130/80	0150-1399

## Kabel Typ

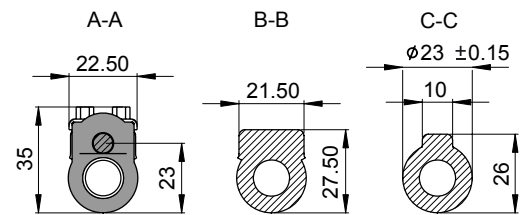
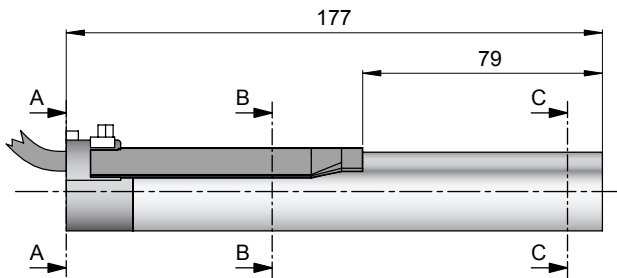

Linearmotor		Stator			Läufer	
Typ	Art. Nr.	Typ	Art. Nr.	Typ	Art. Nr.	
P01-23x80/10x50	-->	PS01-23x80	0150-1201	&	PL01-12x130/80	0150-1399
P01-23x80/10x50-R20	-->	PS01-23x80-R20	0150-1241	&	PL01-12x130/80	0150-1399

## Läufer

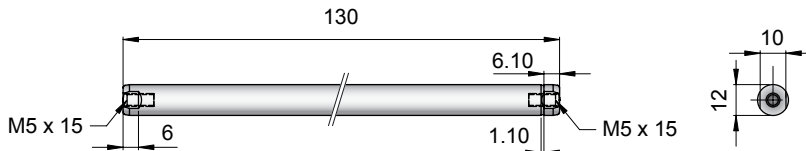

Standard Läufer		Standard Läufer		PL01-12x130/80		0150-1399	
Spezialläufer		Heavy Duty Läufer	mit WC/C-Beschichtung	PL02-12x130/80			0150-1424
		Lochläufer	Innendurchmesser 4.2mm	PL01-12x130/80-L			0150-1445

## Stecker

### Motor Steckerbelegung

Kabellänge:  
P01-23x80/..x.. 1.0m  
P01-23x80/..x..-R20 0.2m

P01-23...-R  
P01-23...-R20

P01-23...  
P01-23...-R20

Ph	Farbe	1	2
Ph 1+	rot	1	1
Ph 1-	pink	2	6
Ph 2+	blau	3	2
Ph 2-	grau	4	7
+5VDC	weiss	A	3
GND	innerer Schirm	B	8
Sinus	gelb	C	4
Cosinus	grün	D	9
Temp.	schwarz	E	5
Schirm	äusserer Schi.	Geh.	Geh.

## Zubehör

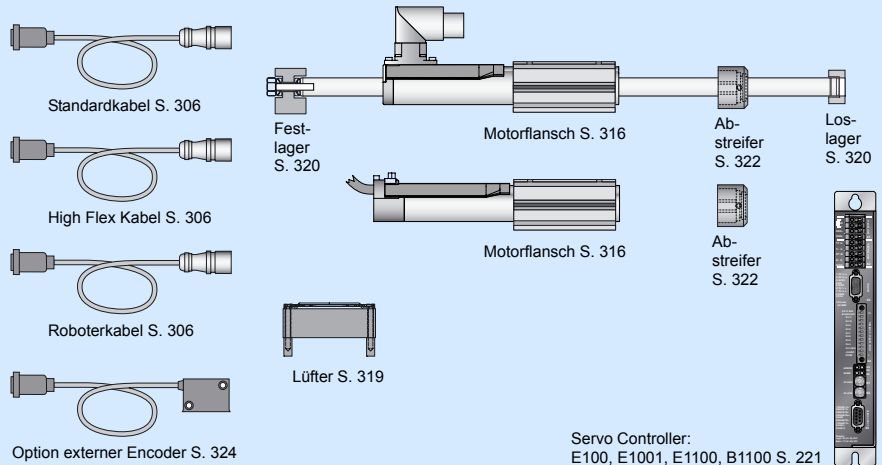

**Maximaler Hub: 90mm**  
**Spitzenkraft: 44N**

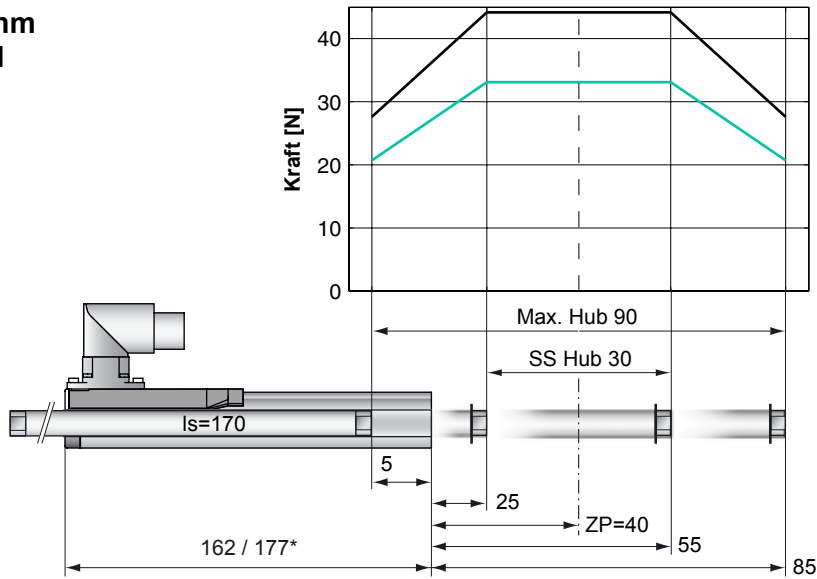

**Standard Wicklung:**

- E1100, 72VDC & E1001, 72VDC
- E100, 48VDC

Abmessungen mm  
 \*Kabel Typ

## Motor Spezifikation

P01-		Stecker Typ	Kabel Typ
		23x80/30x90-R	23x80/30x90 23x80/30x90-R20
Maximaler Hub	mm (in)	90 (3.54)	90 (3.54)
Kurzhubbereich SS	mm (in)	30 (1.18)	30 (1.18)
Spitzenkraft E1100 / E1001	N (lbf)	44 (9.9)	44 (9.9)
Spitzenkraft E100	N (lbf)	33 (7.4)	33 (7.4)
Kont. Kraft	N (lbf)	9 (2.0)	9 (2.0)
Kont. Kraft mit Lüfter	N (lbf)	16 (3.7)	16 (3.7)
Randkraft	%	63	63
Kraftkonstante	N/A (lbf/A)	11.0 (2.48)	11.0 (2.48)
Max. Strom @ 72VDC	A	4.0	4.0
Max. Strom @ 48VDC	A	3.8	3.8
Max. Gesch. @ 72VDC	m/s (in/s)	6.0 (236)	6.0 (236)
Max. Gesch. @ 48VDC	m/s (in/s)	4.0 (157)	4.0 (157)
Phasenwider. 25/80 °C	Ohm	10.3/12.5	10.3/12.5
Phaseninduktivität	mH	1.4	1.4
Therm. Widerstand	°K/W	7.0	7.0
Therm. Zeitkonstante	sec	1600	1600
Statordurchmesser	mm (in)	23 (0.91)	23 (0.91)
Statorlänge	mm (in)	162 (6.38)	177 (6.97)
Statormasse	g (lb)	265 (0.58)	265 (0.58)
Läuferdurchmesser	mm (in)	12 (0.47)	12 (0.47)
Läuferlänge	mm (in)	170 (6.69)	170 (6.69)
Läufermasse	g (lb)	118 (0.26)	118 (0.26)
Wiederholgenauigkeit	mm (in)	±0.05 (±0.0020)	±0.05 (±0.0020)
Linearität	%	±0.45	±0.45
Wiederholgenauigk. ES	mm (in)	±0.01 (±0.0004)	±0.01 (±0.0004)
Linearität ES	mm (in)	±0.01 (±0.0004)	±0.01 (±0.0004)

## Hub-Zeit Diagramm

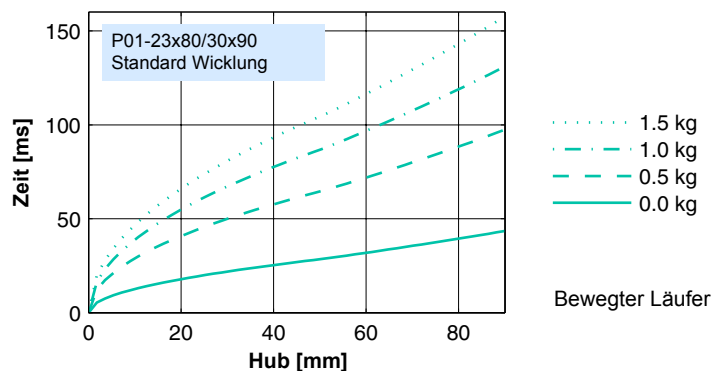

## Stecker Typ

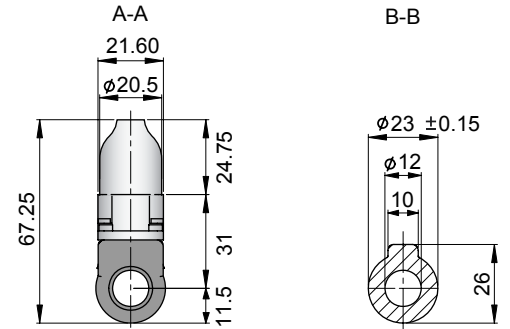
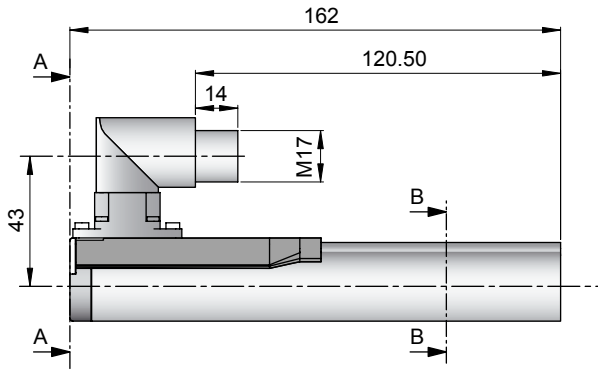

Linearmotor		Stator			Läufer	
Typ	Art. Nr.	Typ	Art. Nr.	Typ	Art. Nr.	
P01-23x80/30x90-R	-->	PS01-23x80-R	0150-1233	&	PL01-12x170/120	0150-1301

## Kabel Typ

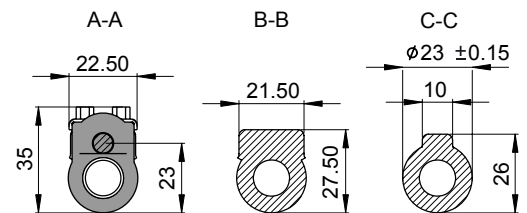
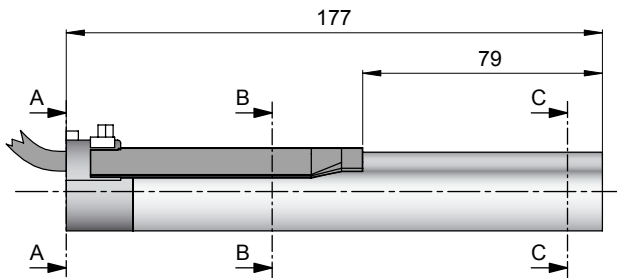

Linearmotor		Stator			Läufer	
Typ	Art. Nr.	Typ	Art. Nr.	Typ	Art. Nr.	
P01-23x80/30x90	-->	PS01-23x80	0150-1201	&	PL01-12x170/120	0150-1301
P01-23x80/30x90-R20	-->	PS01-23x80-R20	0150-1241	&	PL01-12x170/120	0150-1301

## Läufer

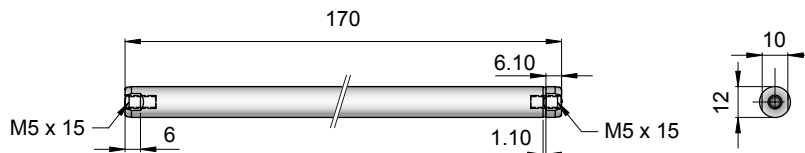

Standard Läufer		Standard Läufer		PL01-12x170/120		0150-1301	
Spezialläufer		Heavy Duty Läufer	mit WC/C-Beschichtung	PL02-12x170/120			0150-1303
		Lochläufer	Innendurchmesser 4.2mm	PL01-12x170/120-L			0150-1375

## Stecker

### Motor Steckerbelegung

Kabellänge:  
P01-23x80/...x... 1.0m  
P01-23x80/...x...-R20 0.2m

		P01-23...-R	P01-23...-R20	P01-23...-R20
Ph 1+	rot	1	1	
Ph 1-	pink	2	6	
Ph 2+	blau	3	2	
Ph 2-	grau	4	7	
+5VDC	weiss	A	3	
GND	innerer Schirm	B	8	
Sinus	gelb	C	4	
Cosinus	grün	D	9	
Temp.	schwarz	E	5	
Schirm	äusserer Schi.	Geh.	Geh.	

## Zubehör

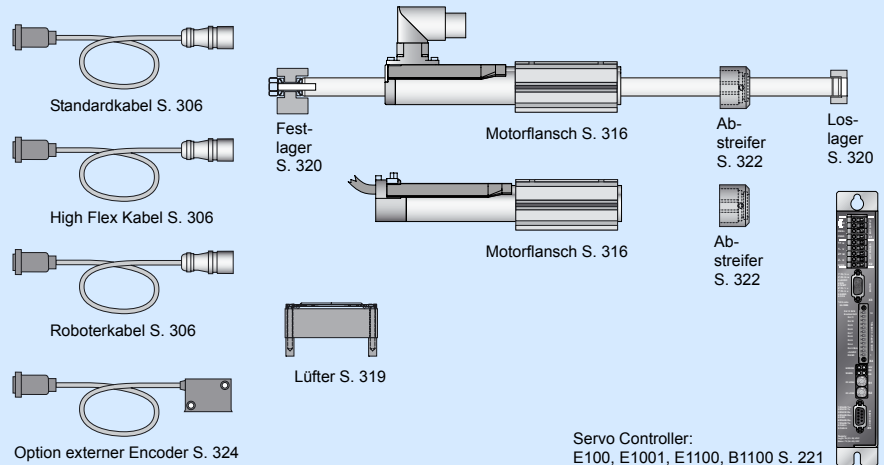

**Maximaler Hub: 110mm**  
**Spitzenkraft: 44N**

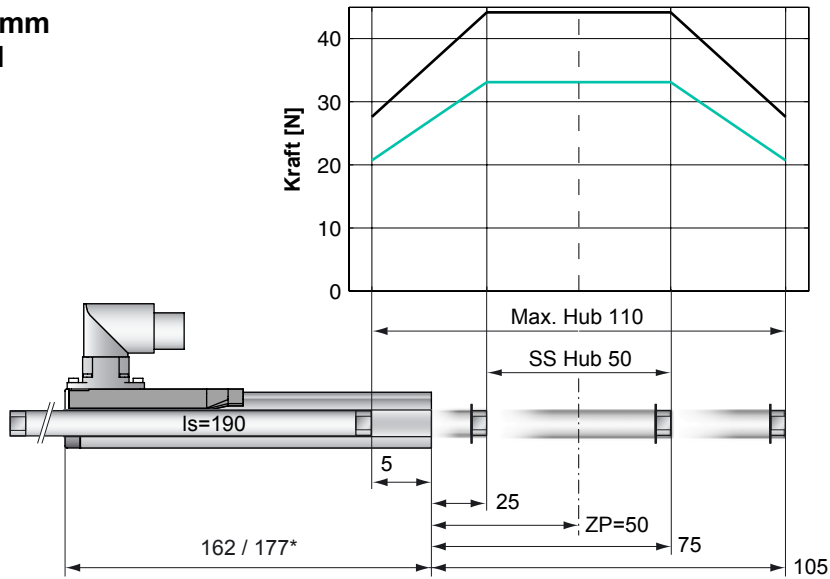

**Standard Wicklung:**  
 — E1100, 72VDC & E1001, 72VDC  
 — E100, 48VDC

Abmessungen mm  
 \*Kabel Typ

## Motor Spezifikation

P01-		Stecker Typ	Kabel Typ
		23x80/50x110-R	23x80/50x110 23x80/50x110-R20
Maximaler Hub	mm (in)	110 (4.33)	110 (4.33)
Kurzhubbereich SS	mm (in)	50 (1.97)	50 (1.97)
Spitzenkraft E1100 / E1001	N (lbf)	44 (9.9)	44 (9.9)
Spitzenkraft E100	N (lbf)	33 (7.4)	33 (7.4)
Kont. Kraft	N (lbf)	9 (2.0)	9 (2.0)
Kont. Kraft mit Lüfter	N (lbf)	16 (3.7)	16 (3.7)
Randkraft	%	63	63
Kraftkonstante	N/A (lbf/A)	11.0 (2.48)	11.0 (2.48)
Max. Strom @ 72VDC	A	4.0	4.0
Max. Strom @ 48VDC	A	3.8	3.8
Max. Gesch. @ 72VDC	m/s (in/s)	6.0 (236)	6.0 (236)
Max. Gesch. @ 48VDC	m/s (in/s)	4.0 (157)	4.0 (157)
Phasenwider. 25/80 °C	Ohm	10.3/12.5	10.3/12.5
Phaseninduktivität	mH	1.4	1.4
Therm. Widerstand	°K/W	7.0	7.0
Therm. Zeitkonstante	sec	1600	1600
Statordurchmesser	mm (in)	23 (0.91)	23 (0.91)
Statorlänge	mm (in)	162 (6.38)	177 (6.97)
Stormasse	g (lb)	265 (0.58)	265 (0.58)
Läuferdurchmesser	mm (in)	12 (0.47)	12 (0.47)
Läuferlänge	mm (in)	190 (7.48)	190 (7.48)
Läufermasse	g (lb)	135 (0.30)	135 (0.30)
Wiederholgenauigkeit	mm (in)	±0.05 (±0.0020)	±0.05 (±0.0020)
Linearität	%	±0.40	±0.40
Wiederholgenauigk. ES	mm (in)	±0.01 (±0.0004)	±0.01 (±0.0004)
Linearität ES	mm (in)	±0.01 (±0.0004)	±0.01 (±0.0004)

## Hub-Zeit Diagramm

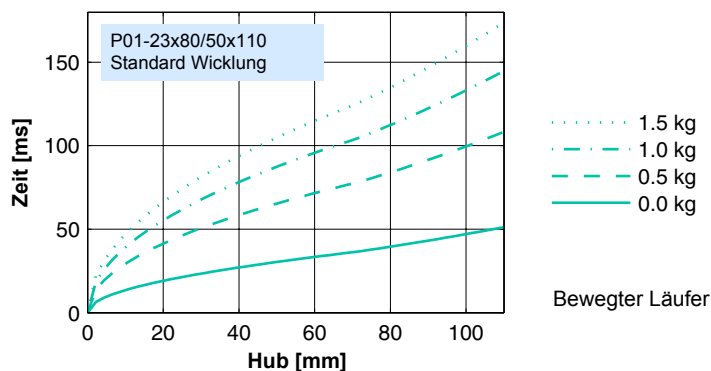

## Stecker Typ

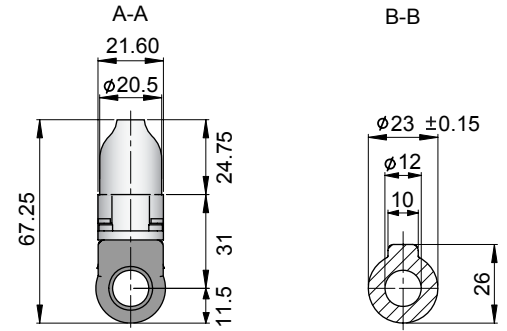
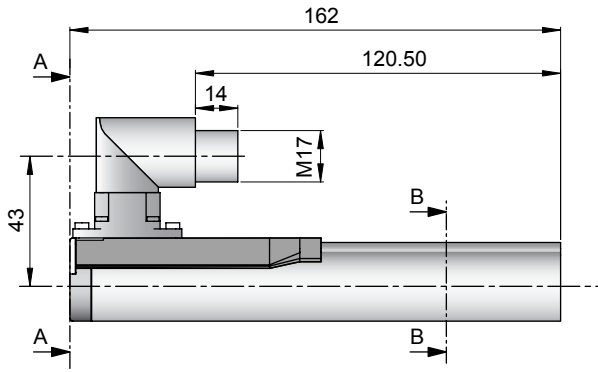

Linearmotor		Stator		Läufer	
Typ	Art. Nr.	Typ	Art. Nr.	Typ	Art. Nr.
P01-23x80/50x110-R	-->	PS01-23x80-R	0150-1233	& PL01-12x190/140	0150-1302

## Kabel Typ

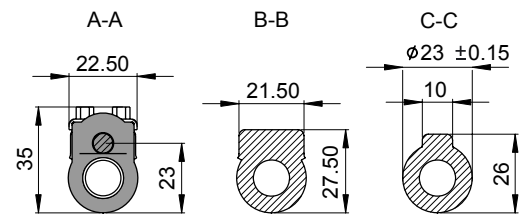

Linearmotor		Stator		Läufer	
Typ	Art. Nr.	Typ	Art. Nr.	Typ	Art. Nr.
P01-23x80/50x110	-->	PS01-23x80	0150-1201	& PL01-12x190/140	0150-1302
P01-23x80/50x110-R20	-->	PS01-23x80-R20	0150-1241	& PL01-12x190/140	0150-1302

## Läufer

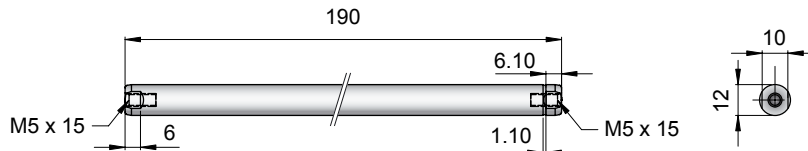

Standard Läufer		Standard Läufer		Läufer	
Typ	Art. Nr.	Typ	Art. Nr.	Typ	Art. Nr.
Standard Läufer		Standard Läufer		PL01-12x190/140	0150-1302
Spezialläufer		Heavy Duty Läufer mit WC/C-Beschichtung		PL02-12x190/140	0150-1304
		Lochläufer Innendurchmesser 4.2mm		PL01-12x190/140-L	0150-1478

## Stecker

### Motor Steckerbelegung

#### Kabellänge:

P01-23x80/... 1.0m  
P01-23x80/...-R20 0.2m

P01-23...-R  
P01-23...-R20

P01-23...  
P01-23...-R20

Ph	Farbe	1	2
Ph 1+	rot	1	1
Ph 1-	pink	2	6
Ph 2+	blau	3	2
Ph 2-	grau	4	7
+5VDC	weiss	A	3
GND	innerer Schirm	B	8
Sinus	gelb	C	4
Cosinus	grün	D	9
Temp.	schwarz	E	5
Schirm	äusserer Schi.	Geh.	Geh.

## Zubehör

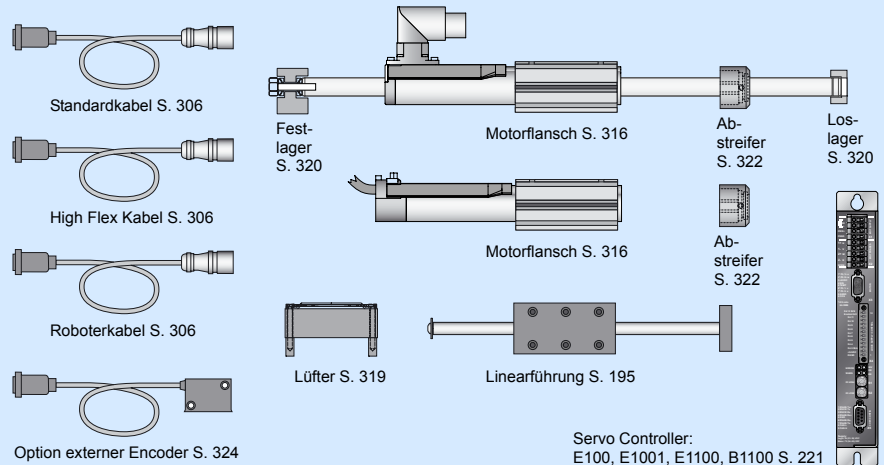

Servo Controller:  
E100, E1001, E1100, B1100 S. 221

**Maximaler Hub: 140mm**  
**Spitzenkraft: 44N**

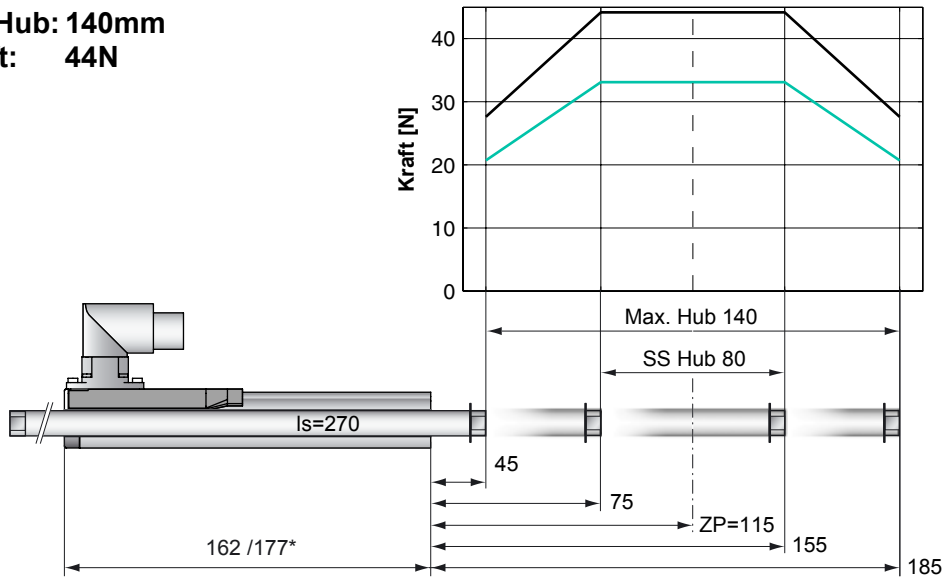

**Standard Wicklung:**

- E1100, 72VDC & E1001, 72VDC
- E100, 48VDC

Abmessungen mm  
 \*Kabel Typ

## Motor Spezifikation

P01-	Stecker Typ		Kabel Typ	
	23x80/80x140-R		23x80/80x140 23x80/80x140-R20	
Maximaler Hub	mm (in)	140 (5.51)	140 (5.51)	140 (5.51)
Kurzhubbereich SS	mm (in)	80 (3.15)	80 (3.15)	80 (3.15)
Spitzenkraft E1100 / E1001	N (lbf)	44 (9.9)	44 (9.9)	44 (9.9)
Spitzenkraft E100	N (lbf)	33 (7.4)	33 (7.4)	33 (7.4)
Kont. Kraft	N (lbf)	9 (2.0)	9 (2.0)	9 (2.0)
Kont. Kraft mit Lüfter	N (lbf)	16 (3.7)	16 (3.7)	16 (3.7)
Randkraft	%	63	63	63
Kraftkonstante	N/A (lbf/A)	11.0 (2.48)	11.0 (2.48)	11.0 (2.48)
Max. Strom @ 72VDC	A	4.0	4.0	4.0
Max. Strom @ 48VDC	A	3.8	3.8	3.8
Max. Gesch. @ 72VDC	m/s (in/s)	6.0 (236)	6.0 (236)	6.0 (236)
Max. Gesch. @ 48VDC	m/s (in/s)	4.0 (157)	4.0 (157)	4.0 (157)
Phasenwider. 25/80 °C	Ohm	10.3/12.5	10.3/12.5	10.3/12.5
Phaseninduktivität	mH	1.4	1.4	1.4
Therm. Widerstand	°K/W	7.0	7.0	7.0
Therm. Zeitkonstante	sec	1600	1600	1600
Statordurchmesser	mm (in)	23 (0.91)	23 (0.91)	23 (0.91)
Statorlänge	mm (in)	162 (6.38)	177 (6.97)	177 (6.97)
Stormasse	g (lb)	265 (0.58)	265 (0.58)	265 (0.58)
Läuferdurchmesser	mm (in)	12 (0.47)	12 (0.47)	12 (0.47)
Läuferlänge	mm (in)	270 (10.63)	270 (10.63)	270 (10.63)
Läufermasse	g (lb)	171 (0.38)	171 (0.38)	171 (0.38)
Wiederholgenauigkeit	mm (in)	±0.05 (±0.0020)	±0.05 (±0.0020)	±0.05 (±0.0020)
Linearität	%	±0.35	±0.35	±0.35
Wiederholgenauigk. ES	mm (in)	±0.01 (±0.0004)	±0.01 (±0.0004)	±0.01 (±0.0004)
Linearität ES	mm (in)	±0.01 (±0.0004)	±0.01 (±0.0004)	±0.01 (±0.0004)

## Hub-Zeit Diagramm

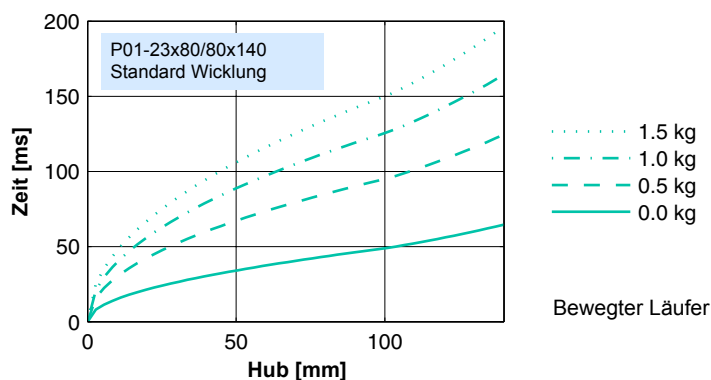

## Stecker Typ

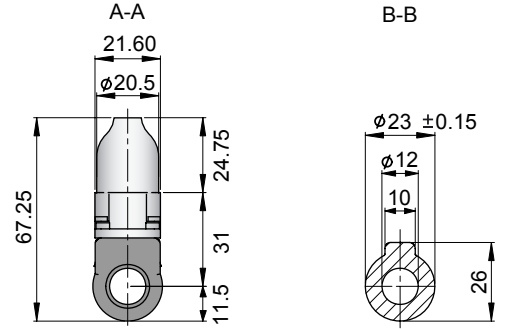
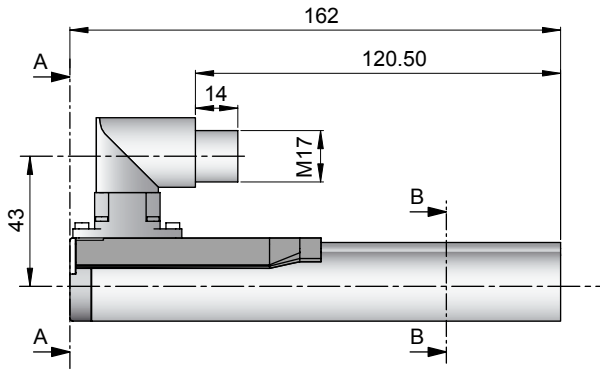

Linearmotor		Stator			Läufer	
Typ	Art. Nr.	Typ	Art. Nr.	Typ	Art. Nr.	
P01-23x80/80x140-R	-->	PS01-23x80-R	0150-1233	&	PL01-12x270/170	0150-1307

## Kabel Typ

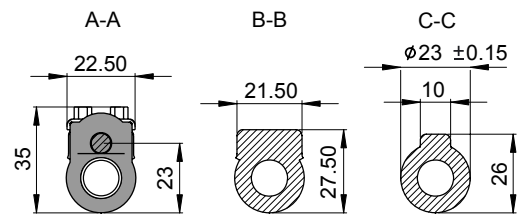
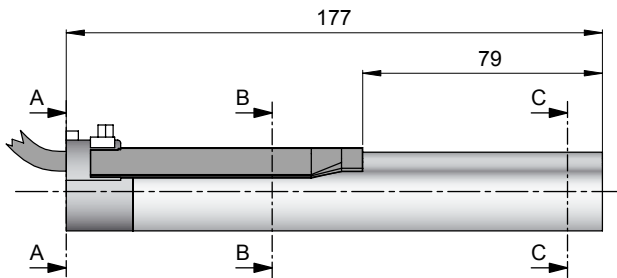

Linearmotor		Stator			Läufer	
Typ	Art. Nr.	Typ	Art. Nr.	Typ	Art. Nr.	
P01-23x80/80x140	-->	PS01-23x80	0150-1201	&	PL01-12x270/170	0150-1307
P01-23x80/80x140-R20	-->	PS01-23x80-R20	0150-1241	&	PL01-12x270/170	0150-1307

## Läufer

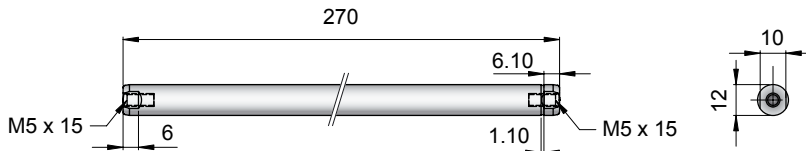

Standard Läufer		Standard Läufer		PL01-12x270/170		0150-1307	
Spezialläufer		Heavy Duty Läufer	mit WC/C-Beschichtung	PL02-12x270/170			0150-1310
		Lochläufer	Innendurchmesser 4.2mm	PL01-12x270/170-L			0150-1393

## Stecker

### Motor Steckerbelegung

Kabellänge:  
P01-23x80/..x.. 1.0m  
P01-23x80/..x..-R20 0.2m

		P01-23...-R	P01-23...-R20	P01-23....
Ph 1+	rot	1	1	
Ph 1-	pink	2	6	
Ph 2+	blau	3	2	
Ph 2-	grau	4	7	
+5VDC	weiss	A	3	
GND	innerer Schirm	B	8	
Sinus	gelb	C	4	
Cosinus	grün	D	9	
Temp.	schwarz	E	5	
Schirm	äusserer Schi.	Geh.	Geh.	

## Zubehör

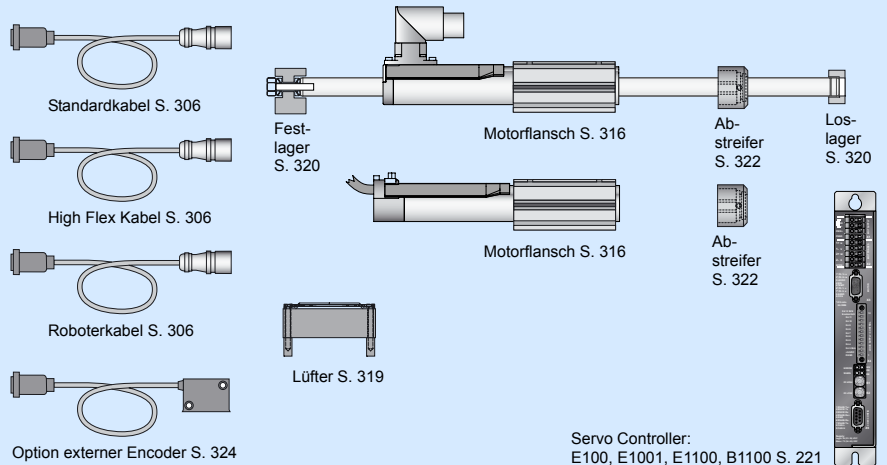

**Maximaler Hub: 210mm**  
**Spitzenkraft: 44N**

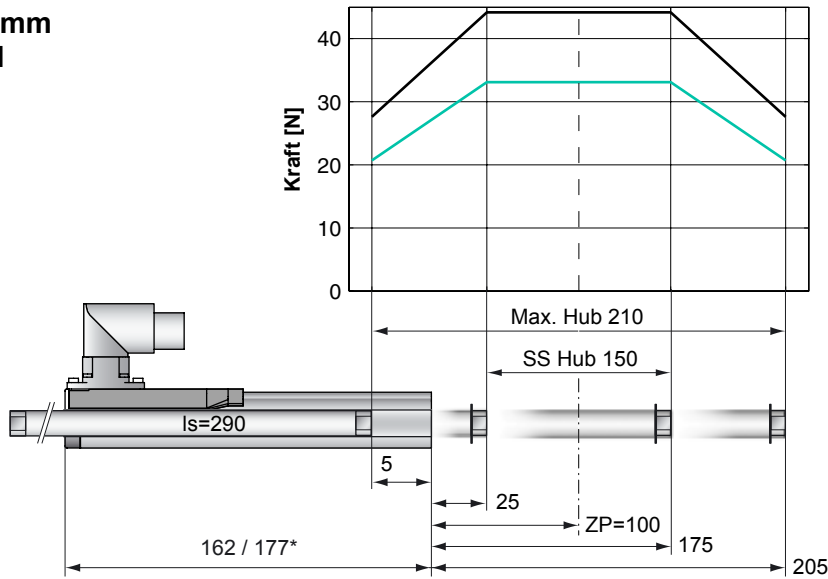

**Standard Wicklung:**

- E1100, 72VDC & E1001, 72VDC
- E100, 48VDC

Abmessungen mm  
 \*Kabel Typ

## Motor Spezifikation

P01-		Stecker Typ	Kabel Typ
		23x80/150x210-R	23x80/150x210 23x80/150x210-R20
Maximaler Hub	mm (in)	210 (8.27)	210 (8.27)
Kurzhubbereich SS	mm (in)	150 (5.91)	150 (5.91)
Spitzenkraft E1100 / E1001	N (lbf)	44 (9.9)	44 (9.9)
Spitzenkraft E100	N (lbf)	33 (7.4)	33 (7.4)
Kont. Kraft	N (lbf)	9 (2.0)	9 (2.0)
Kont. Kraft mit Lüfter	N (lbf)	16 (3.7)	16 (3.7)
Randkraft	%	63	63
Kraftkonstante	N/A (lbf/A)	11.0 (2.48)	11.0 (2.48)
Max. Strom @ 72VDC	A	4.0	4.0
Max. Strom @ 48VDC	A	3.8	3.8
Max. Gesch. @ 72VDC	m/s (in/s)	6.0 (236)	6.0 (236)
Max. Gesch. @ 48VDC	m/s (in/s)	4.0 (157)	4.0 (157)
Phasenwider. 25/80 °C	Ohm	10.3/12.5	10.3/12.5
Phaseninduktivität	mH	1.4	1.4
Therm. Widerstand	°K/W	7.0	7.0
Therm. Zeitkonstante	sec	1600	1600
Statordurchmesser	mm (in)	23 (0.91)	23 (0.91)
Statorlänge	mm (in)	162 (6.38)	177 (6.97)
Stormasse	g (lb)	265 (0.58)	265 (0.58)
Läuferdurchmesser	mm (in)	12 (0.47)	12 (0.47)
Läuferlänge	mm (in)	290 (11.42)	290 (11.42)
Läufermasse	g (lb)	220 (0.49)	220 (0.49)
Wiederholgenauigkeit	mm (in)	±0.05 (±0.0020)	±0.05 (±0.0020)
Linearität	%	±0.30	±0.30
Wiederholgenauigk. ES	mm (in)	±0.01 (±0.0004)	±0.01 (±0.0004)
Linearität ES	mm (in)	±0.01 (±0.0004)	±0.01 (±0.0004)

## Hub-Zeit Diagramm

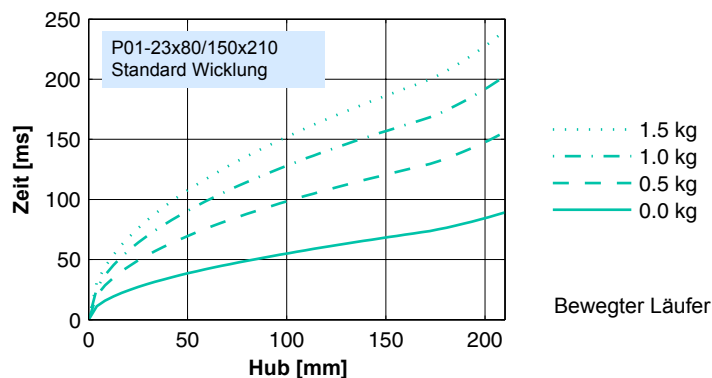

## Stecker Typ

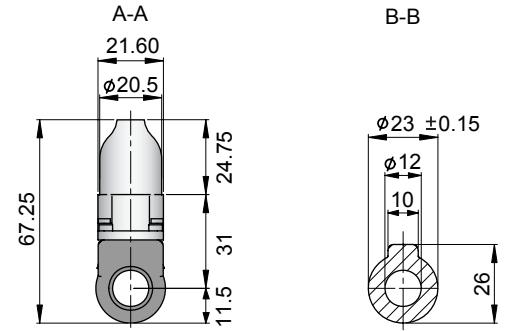
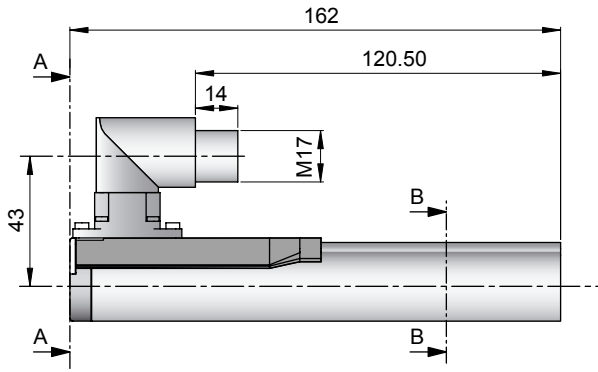

Linearmotor		Stator		Läufer	
Typ	Art. Nr.	Typ	Art. Nr.	Typ	Art. Nr.
P01-23x80/150x210-R	-->	PS01-23x80-R	0150-1233	& PL01-12x290/240	0150-1320

## Kabel Typ

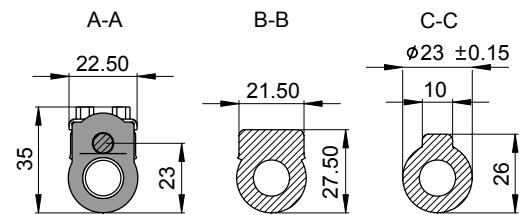
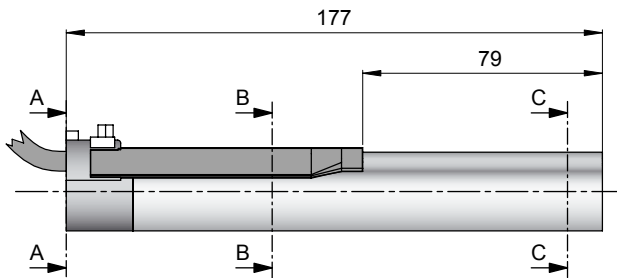

Linearmotor		Stator		Läufer	
Typ	Art. Nr.	Typ	Art. Nr.	Typ	Art. Nr.
P01-23x80/150x210	-->	PS01-23x80	0150-1201	& PL01-12x290/240	0150-1320
P01-23x80/150x210-R20	-->	PS01-23x80-R20	0150-1241	& PL01-12x290/240	0150-1320

## Läufer

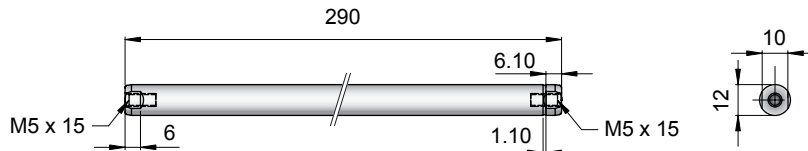

Standard Läufer		Standard Läufer		PL01-12x290/240	
Typ	Art. Nr.	Typ	Art. Nr.	Typ	Art. Nr.
Standard Läufer		Standard Läufer		PL01-12x290/240	0150-1320
Spezialläufer		Heavy Duty Läufer mit WC/C-Beschichtung		PL02-12x290/240	0150-1321
		Lochläufer Innendurchmesser 4.2mm		PL01-12x290/240-L	0150-1363

## Stecker

### Motor Steckerbelegung

Kabellänge:  
P01-23x80/...x... 1.0m  
P01-23x80/...x...-R20 0.2m

Ph	Farbe	P01-23...-R	P01-23...-R20	P01-23...-R20
Ph 1+	rot	1	1	1
Ph 1-	pink	2	6	6
Ph 2+	blau	3	2	2
Ph 2-	grau	4	7	7
+5VDC	weiss	A	3	3
GND	innerer Schirm	B	8	8
Sinus	gelb	C	4	4
Cosinus	grün	D	9	9
Temp.	schwarz	E	5	5
Schirm	äusserer Schi.	Geh.	Geh.	Geh.

## Zubehör

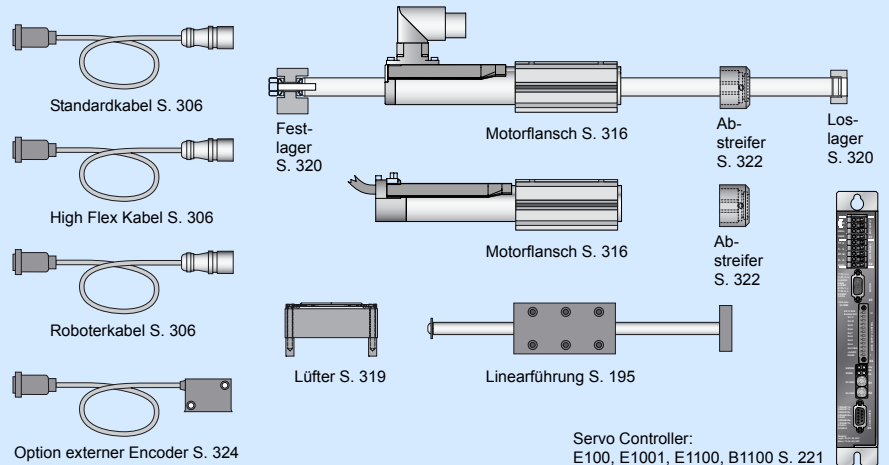

**Maximaler Hub: 270mm**  
**Spitzenkraft: 44N**

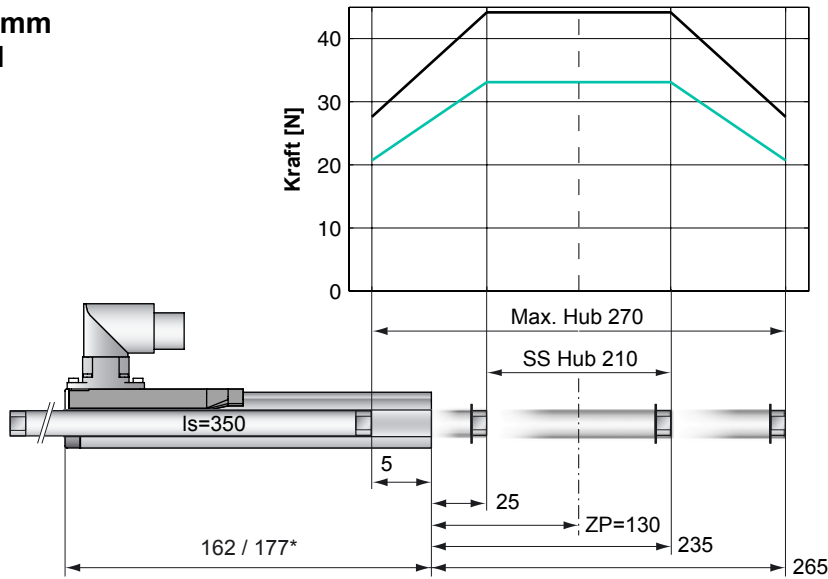

**Standard Wicklung:**

- E1100, 72VDC & E1001, 72VDC
- E100, 48VDC

Abmessungen mm  
 \*Kabel Typ

## Motor Spezifikation

P01-		Stecker Typ	Kabel Typ
		23x80/210x270-R	23x80/210x270 23x80/210x270-R20
Maximaler Hub	mm (in)	270 (10.63)	270 (10.63)
Kurzhubbereich SS	mm (in)	210 (8.27)	210 (8.27)
Spitzenkraft E1100 / E1001	N (lbf)	44 (9.9)	44 (9.9)
Spitzenkraft E100	N (lbf)	33 (7.4)	33 (7.4)
Kont. Kraft	N (lbf)	9 (2.0)	9 (2.0)
Kont. Kraft mit Lüfter	N (lbf)	16 (3.7)	16 (3.7)
Randkraft	%	63	63
Kraftkonstante	N/A (lbf/A)	11.0 (2.48)	11.0 (2.48)
Max. Strom @ 72VDC	A	4.0	4.0
Max. Strom @ 48VDC	A	3.8	3.8
Max. Gesch. @ 72VDC	m/s (in/s)	6.0 (236)	6.0 (236)
Max. Gesch. @ 48VDC	m/s (in/s)	4.0 (157)	4.0 (157)
Phasenwider. 25/80 °C	Ohm	10.3/12.5	10.3/12.5
Phaseninduktivität	mH	1.4	1.4
Therm. Widerstand	°K/W	7.0	7.0
Therm. Zeitkonstante	sec	1600	1600
Statordurchmesser	mm (in)	23 (0.91)	23 (0.91)
Statorlänge	mm (in)	162 (6.38)	177 (6.97)
Stormasse	g (lb)	265 (0.58)	265 (0.58)
Läuferdurchmesser	mm (in)	12 (0.47)	12 (0.47)
Läuferlänge	mm (in)	350 (13.78)	350 (13.78)
Läufermasse	g (lb)	271 (0.60)	271 (0.60)
Wiederholgenauigkeit	mm (in)	±0.05 (±0.0020)	±0.05 (±0.0020)
Linearität	%	±0.25	±0.25
Wiederholgenauigk. ES	mm (in)	±0.01 (±0.0004)	±0.01 (±0.0004)
Linearität ES	mm (in)	±0.01 (±0.0004)	±0.01 (±0.0004)

## Hub-Zeit Diagramm

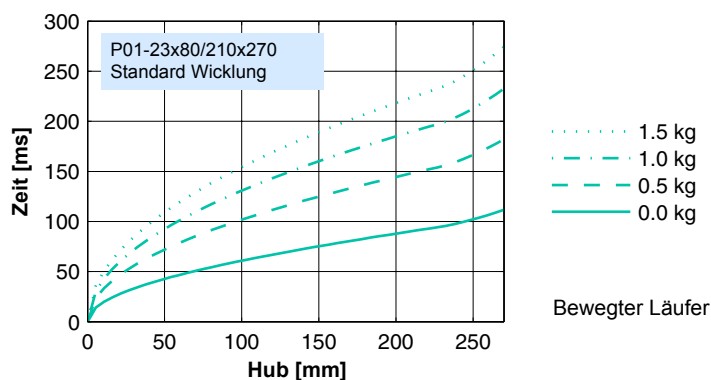

## Stecker Typ

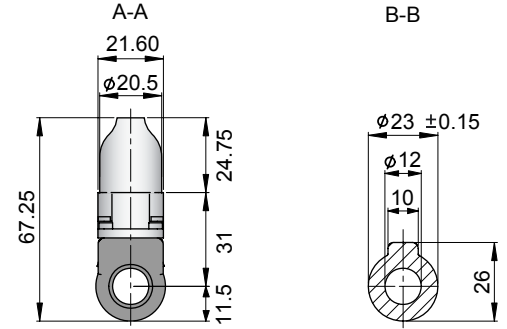
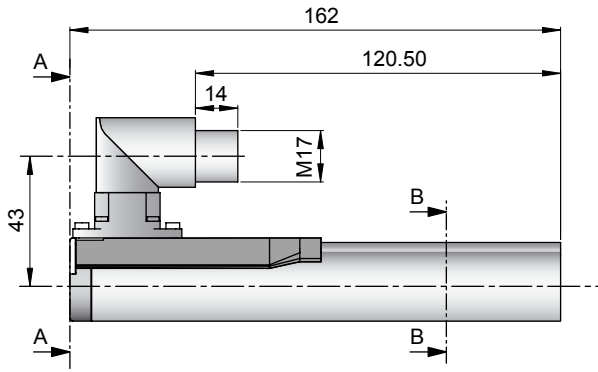

Linearmotor		Stator		Läufer	
Typ	Art. Nr.	Typ	Art. Nr.	Typ	Art. Nr.
P01-23x80/210x270-R	-->	PS01-23x80-R	0150-1233	& PL01-12x350/300	0150-1322

## Kabel Typ

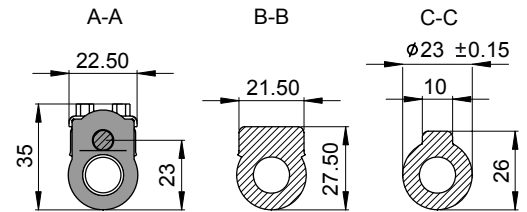
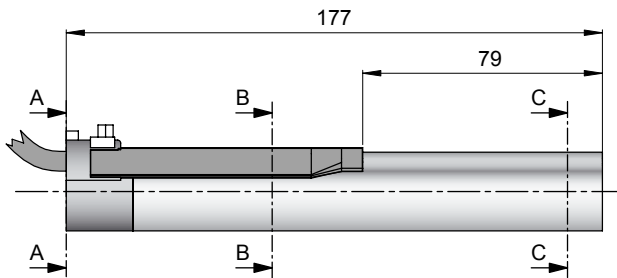

Linearmotor		Stator		Läufer	
Typ	Art. Nr.	Typ	Art. Nr.	Typ	Art. Nr.
P01-23x80/210x270	-->	PS01-23x80	0150-1201	& PL01-12x350/300	0150-1322
P01-23x80/210x270-R20	-->	PS01-23x80-R20	0150-1241	& PL01-12x350/300	0150-1322

## Läufer

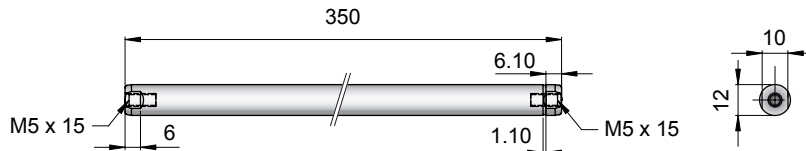

Standard Läufer		Standard Läufer		Läufer	
Typ	Art. Nr.	Typ	Art. Nr.	Typ	Art. Nr.
Standard Läufer		Standard Läufer		PL01-12x350/300	0150-1322
Spezialläufer		Heavy Duty Läufer mit WC/C-Beschichtung		PL02-12x350/300	0150-1323
		Lochläufer Innendurchmesser 4.2mm		PL01-12x350/300-L	0150-1479

## Stecker

### Motor Steckerbelegung

Kabellänge:  
P01-23x80/... 1.0m  
P01-23x80/...-R20 0.2m

		P01-23...-R	P01-23...-R20	P01-23...
Ph 1+	rot	1	1	
Ph 1-	pink	2	6	
Ph 2+	blau	3	2	
Ph 2-	grau	4	7	
+5VDC	weiss	A	3	
GND	innerer Schirm	B	8	
Sinus	gelb	C	4	
Cosinus	grün	D	9	
Temp.	schwarz	E	5	
Schirm	äusserer Schi.	Geh.	Geh.	

## Zubehör

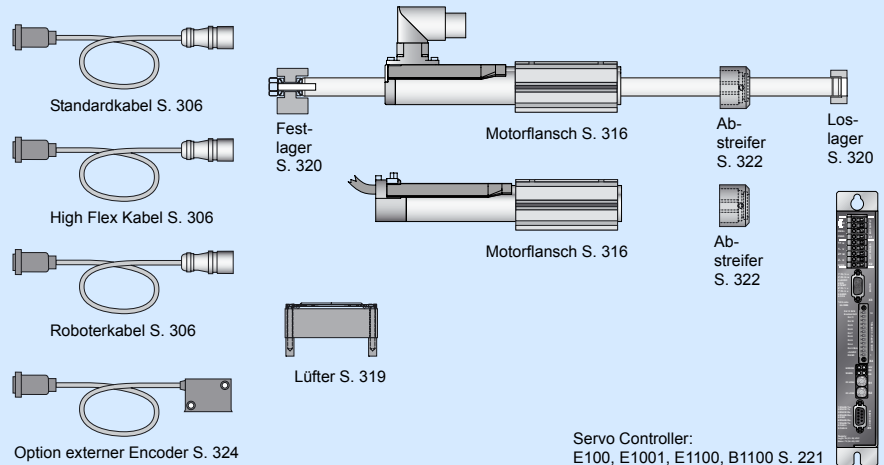

**Maximaler Hub: 340mm**  
**Spitzenkraft: 44N**

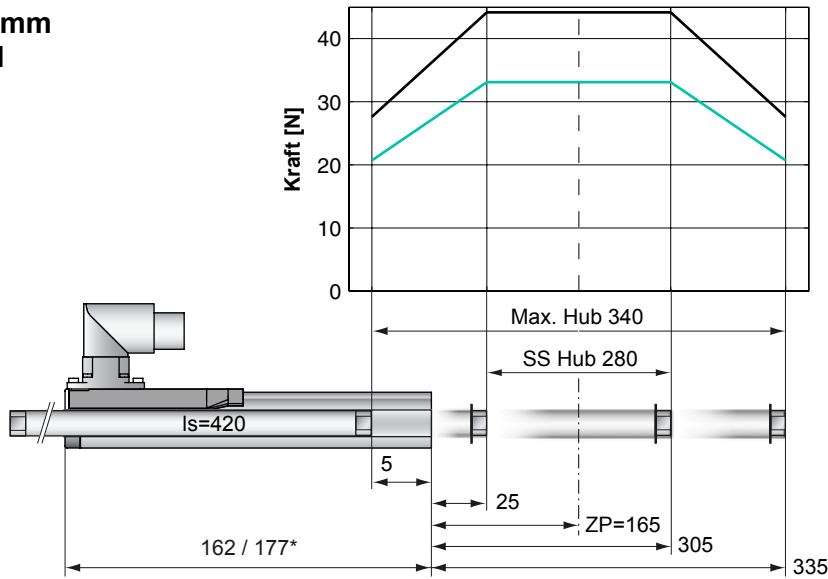

**Standard Wicklung:**

- E1100, 72VDC & E1001, 72VDC
- E100, 48VDC

Abmessungen mm  
 \*Kabel Typ

## Motor Spezifikation

P01-		Stecker Typ	Kabel Typ
		23x80/280x340-R	23x80/280x340 23x80/280x340-R20
Maximaler Hub	mm (in)	340 (13.39)	340 (13.39)
Kurzhubbereich SS	mm (in)	280 (11.02)	280 (11.02)
Spitzenkraft E1100 / E1001	N (lbf)	44 (9.9)	44 (9.9)
Spitzenkraft E100	N (lbf)	33 (7.4)	33 (7.4)
Kont. Kraft	N (lbf)	9 (2.0)	9 (2.0)
Kont. Kraft mit Lüfter	N (lbf)	16 (3.7)	16 (3.7)
Randkraft	%	63	63
Kraftkonstante	N/A (lbf/A)	11.0 (2.48)	11.0 (2.48)
Max. Strom @ 72VDC	A	4.0	4.0
Max. Strom @ 48VDC	A	3.8	3.8
Max. Gesch. @ 72VDC	m/s (in/s)	6.0 (236)	6.0 (236)
Max. Gesch. @ 48VDC	m/s (in/s)	4.0 (157)	4.0 (157)
Phasenwider. 25/80 °C	Ohm	10.3/12.5	10.3/12.5
Phaseninduktivität	mH	1.4	1.4
Therm. Widerstand	°K/W	7.0	7.0
Therm. Zeitkonstante	sec	1600	1600
Statordurchmesser	mm (in)	23 (0.91)	23 (0.91)
Statorlänge	mm (in)	162 (6.38)	177 (6.97)
Stormasse	g (lb)	265 (0.58)	265 (0.58)
Läuferdurchmesser	mm (in)	12 (0.47)	12 (0.47)
Läuferlänge	mm (in)	420 (16.54)	420 (16.54)
Läufermasse	g (lb)	330 (0.73)	330 (0.73)
Wiederholgenauigkeit	mm (in)	±0.05 (±0.0020)	±0.05 (±0.0020)
Linearität	%	±0.25	±0.25
Wiederholgenauigk. ES	mm (in)	±0.01 (±0.0004)	±0.01 (±0.0004)
Linearität ES	mm (in)	±0.01 (±0.0004)	±0.01 (±0.0004)

## Hub-Zeit Diagramm

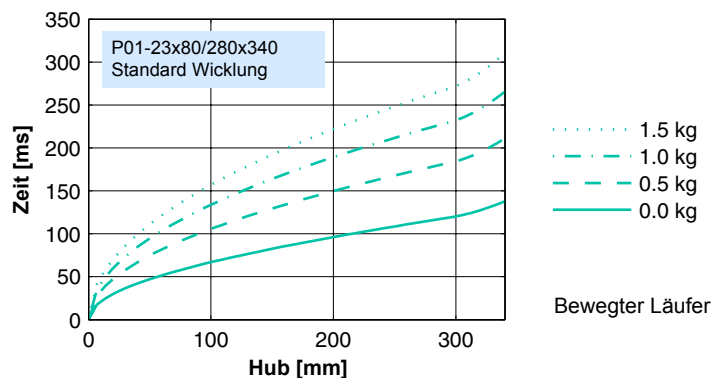

## Stecker Typ

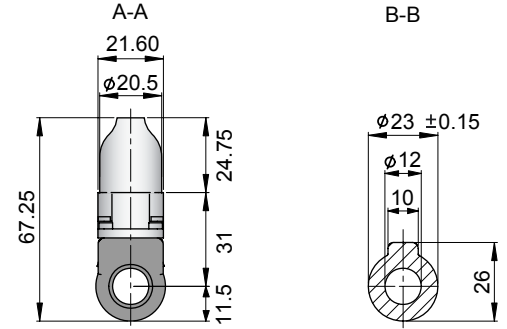
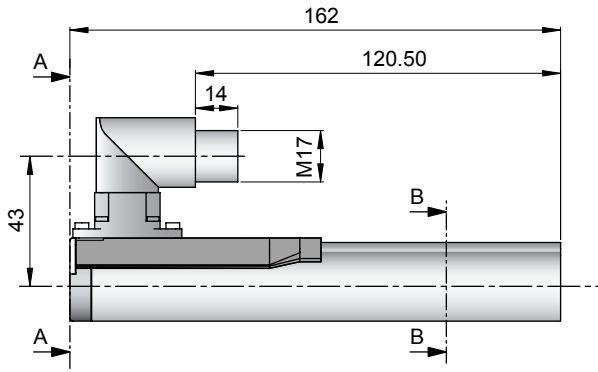

Linearmotor		Stator		Läufer	
Typ	Art. Nr.	Typ	Art. Nr.	Typ	Art. Nr.
P01-23x80/280x340-R	-->	PS01-23x80-R	0150-1233	& PL01-12x420/370	0150-1324

## Kabel Typ

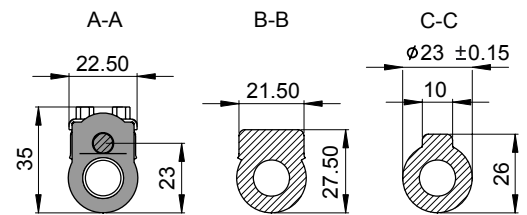
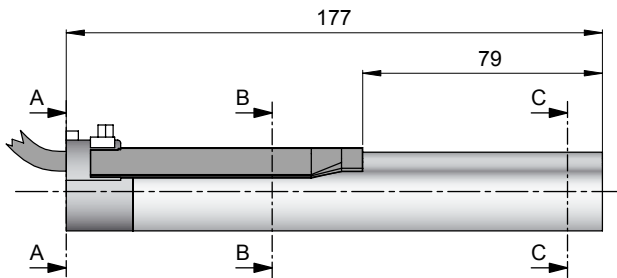

Linearmotor		Stator		Läufer	
Typ	Art. Nr.	Typ	Art. Nr.	Typ	Art. Nr.
P01-23x80/280x340	-->	PS01-23x80	0150-1201	& PL01-12x420/370	0150-1324
P01-23x80/280x340-R20	-->	PS01-23x80-R20	0150-1241	& PL01-12x420/370	0150-1324

## Läufer

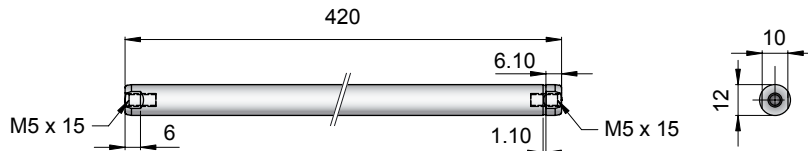

Standard Läufer		Standard Läufer		PL01-12x420/370		0150-1324	
Spezialläufer		Heavy Duty Läufer	mit WC/C-Beschichtung	PL02-12x420/370			0150-1325
		Lochläufer	Innendurchmesser 4.2mm	PL01-12x420/370-L			0150-1394

## Stecker

### Motor Steckerbelegung

Kabellänge:  
P01-23x80/...x... 1.0m  
P01-23x80/...x...-R20 0.2m

		P01-23...-R	P01-23...-R20	P01-23...-R20
Ph 1+	rot	1	1	1
Ph 1-	pink	2	6	6
Ph 2+	blau	3	2	2
Ph 2-	grau	4	7	7
+5VDC	weiss	A	3	3
GND	innerer Schirm	B	8	8
Sinus	gelb	C	4	4
Cosinus	grün	D	9	9
Temp.	schwarz	E	5	5
Schirm	äusserer Schi.	Geh.	Geh.	Geh.

## Zubehör

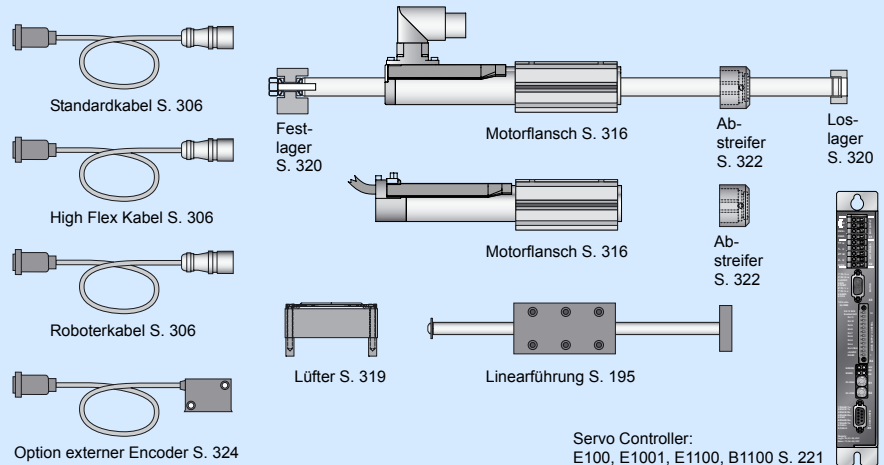

**Maximaler Hub: 400mm**  
**Spitzenkraft: 44N**

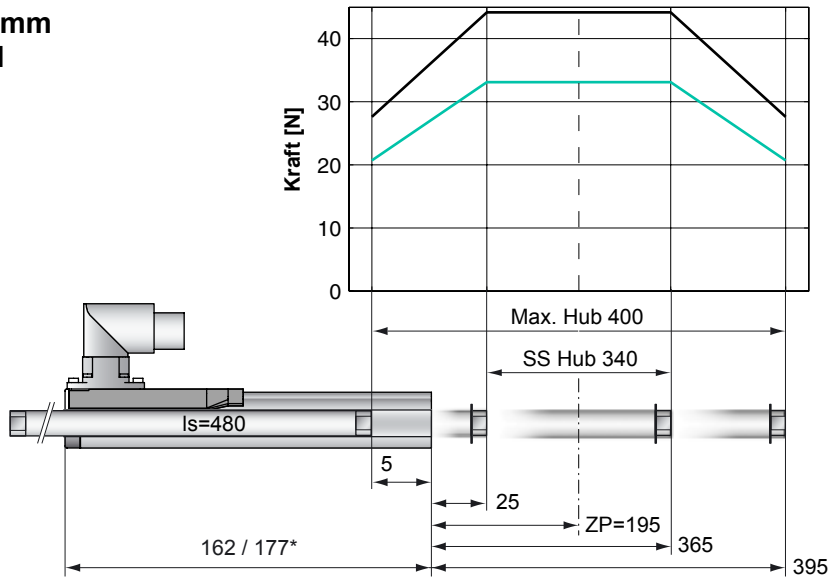

**Standard Wicklung:**

- E1100, 72VDC & E1001, 72VDC
- E100, 48VDC

Abmessungen mm  
 \*Kabel Typ

## Motor Spezifikation

P01-	Stecker Typ		Kabel Typ	
	23x80/340x400-R		23x80/340x400 23x80/340x400-R20	
Maximaler Hub	mm (in)	400 (15.75)	400 (15.75)	400 (15.75)
Kurzhubbereich SS	mm (in)	340 (13.39)	340 (13.39)	340 (13.39)
Spitzenkraft E1100 / E1001	N (lbf)	44 (9.9)	44 (9.9)	44 (9.9)
Spitzenkraft E100	N (lbf)	33 (7.4)	33 (7.4)	33 (7.4)
Kont. Kraft	N (lbf)	9 (2.0)	9 (2.0)	9 (2.0)
Kont. Kraft mit Lüfter	N (lbf)	16 (3.7)	16 (3.7)	16 (3.7)
Randkraft	%	63	63	63
Kraftkonstante	N/A (lbf/A)	11.0 (2.48)	11.0 (2.48)	11.0 (2.48)
Max. Strom @ 72VDC	A	4.0	4.0	4.0
Max. Strom @ 48VDC	A	3.8	3.8	3.8
Max. Gesch. @ 72VDC	m/s (in/s)	6.0 (236)	6.0 (236)	6.0 (236)
Max. Gesch. @ 48VDC	m/s (in/s)	4.0 (157)	4.0 (157)	4.0 (157)
Phasenwider. 25/80 °C	Ohm	10.3/12.5	10.3/12.5	10.3/12.5
Phaseninduktivität	mH	1.4	1.4	1.4
Therm. Widerstand	°K/W	7.0	7.0	7.0
Therm. Zeitkonstante	sec	1600	1600	1600
Statordurchmesser	mm (in)	23 (0.91)	23 (0.91)	23 (0.91)
Statorlänge	mm (in)	162 (6.38)	177 (6.97)	177 (6.97)
Stormasse	g (lb)	265 (0.58)	265 (0.58)	265 (0.58)
Läuferdurchmesser	mm (in)	12 (0.47)	12 (0.47)	12 (0.47)
Läuferlänge	mm (in)	480 (18.90)	480 (18.90)	480 (18.90)
Läufermasse	g (lb)	380 (0.84)	380 (0.84)	380 (0.84)
Wiederholgenauigkeit	mm (in)	±0.05 (±0.0020)	±0.05 (±0.0020)	±0.05 (±0.0020)
Linearität	%	±0.25	±0.25	±0.25
Wiederholgenauigk. ES	mm (in)	±0.01 (±0.0004)	±0.01 (±0.0004)	±0.01 (±0.0004)
Linearität ES	mm (in)	±0.01 (±0.0004)	±0.01 (±0.0004)	±0.01 (±0.0004)

## Hub-Zeit Diagramm

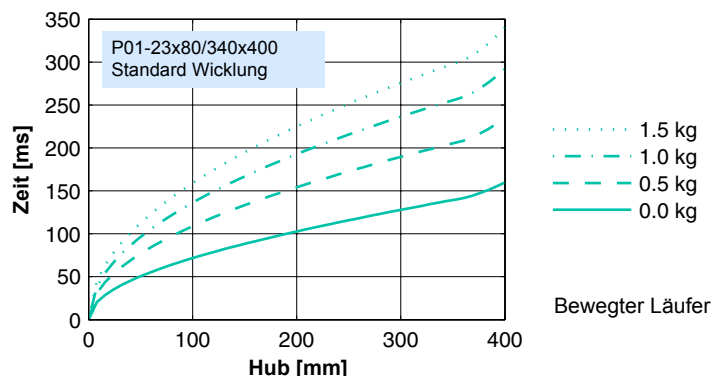

## Stecker Typ

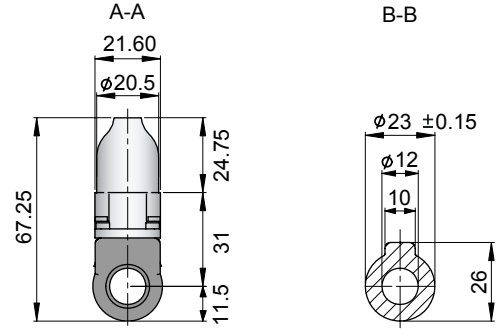
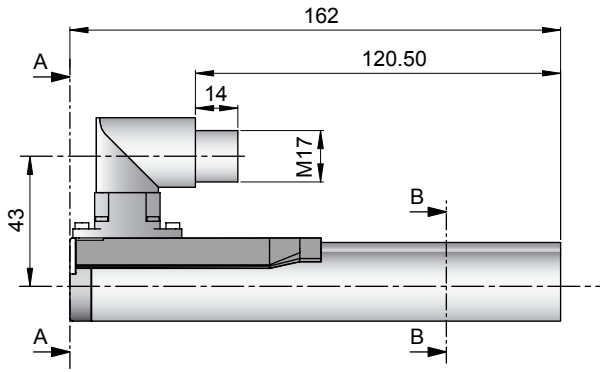

Linearmotor		Stator		Läufer	
Typ	Art. Nr.	Typ	Art. Nr.	Typ	Art. Nr.
P01-23x80/340x400-R	-->	PS01-23x80-R	0150-1233	& PL01-12x480/430	0150-1372

## Kabel Typ

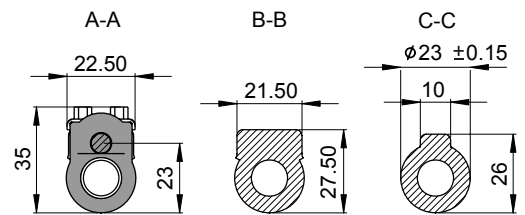
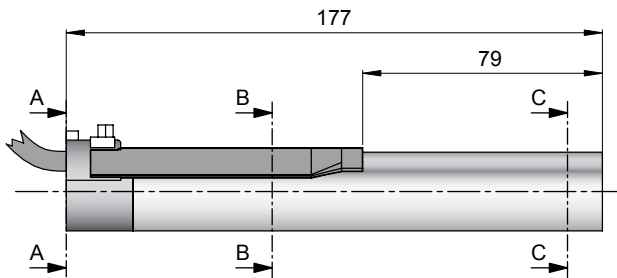

Linearmotor		Stator		Läufer	
Typ	Art. Nr.	Typ	Art. Nr.	Typ	Art. Nr.
P01-23x80/340x400	-->	PS01-23x80	0150-1201	& PL01-12x480/430	0150-1372
P01-23x80/340x400-R20	-->	PS01-23x80-R20	0150-1241	& PL01-12x480/430	0150-1372

## Läufer

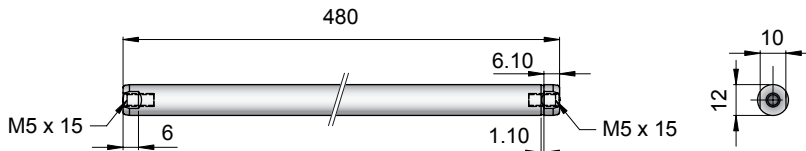

Standard Läufer		Standard Läufer		PL01-12x480/430		0150-1372	
Spezialläufer		Heavy Duty Läufer	mit WC/C-Beschichtung	PL02-12x480/430			0150-1373
		Lochläufer	Innendurchmesser 4.2mm	PL01-12x480/430-L			auf Anfrage

## Stecker

### Motor Steckerbelegung

Kabellänge:  
P01-23x80/...x... 1.0m  
P01-23x80/...x...-R20 0.2m

		P01-23...-R	P01-23...-R20	P01-23...-
Ph 1+	rot	1	1	
Ph 1-	pink	2	6	
Ph 2+	blau	3	2	
Ph 2-	grau	4	7	
+5VDC	weiss	A	3	
GND	innerer Schirm	B	8	
Sinus	gelb	C	4	
Cosinus	grün	D	9	
Temp.	schwarz	E	5	
Schirm	äusserer Schi.	Geh.	Geh.	

## Zubehör

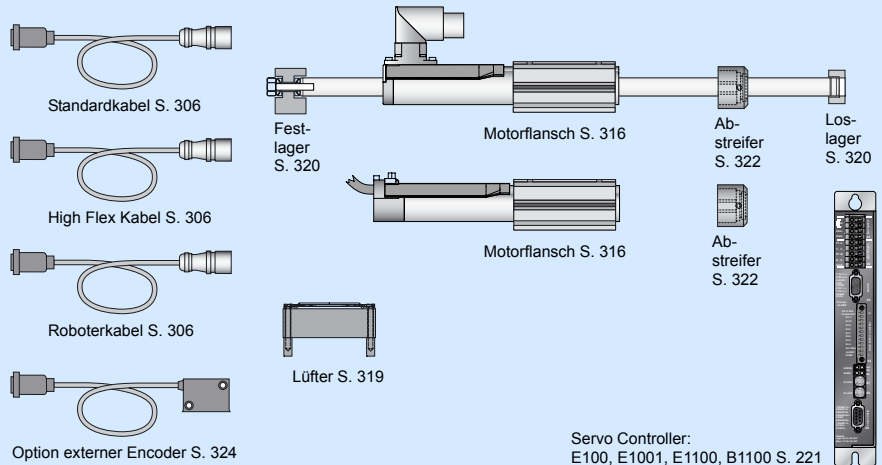

**Maximaler Hub: 500mm**  
**Spitzenkraft: 44N**

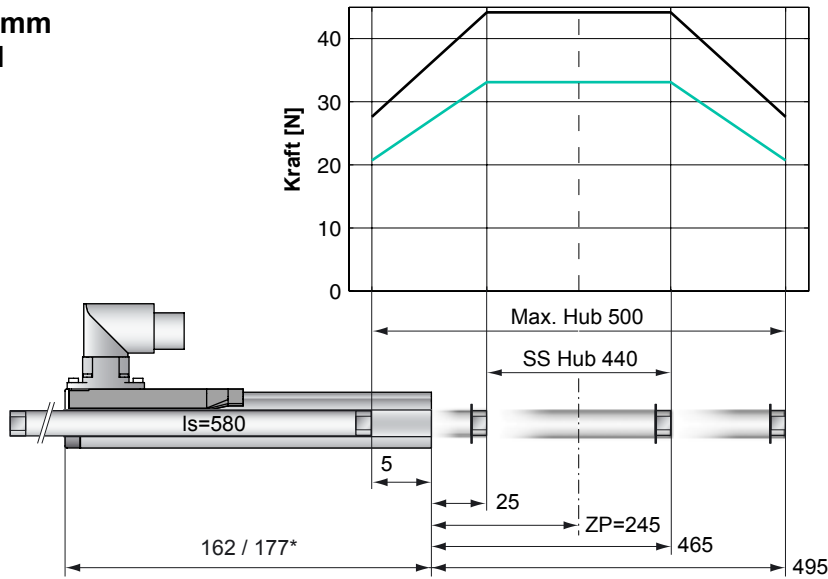

**Standard Wicklung:**

- E1100, 72VDC & E1001, 72VDC
- E100, 48VDC

Abmessungen mm  
 \*Kabel Typ

## Motor Spezifikation

P01-		Stecker Typ	Kabel Typ
		23x80/440x500-R	23x80/440x500 23x80/440x500-R20
Maximaler Hub	mm (in)	500 (19.69)	500 (19.69)
Kurzhubbereich SS	mm (in)	440 (17.32)	440 (17.32)
Spitzenkraft E1100 / E1001	N (lbf)	44 (9.9)	44 (9.9)
Spitzenkraft E100	N (lbf)	33 (7.4)	33 (7.4)
Kont. Kraft	N (lbf)	9 (2.0)	9 (2.0)
Kont. Kraft mit Lüfter	N (lbf)	16 (3.7)	16 (3.7)
Randkraft	%	63	63
Kraftkonstante	N/A (lbf/A)	11.0 (2.48)	11.0 (2.48)
Max. Strom @ 72VDC	A	4.0	4.0
Max. Strom @ 48VDC	A	3.8	3.8
Max. Gesch. @ 72VDC	m/s (in/s)	6.0 (236)	6.0 (236)
Max. Gesch. @ 48VDC	m/s (in/s)	4.0 (157)	4.0 (157)
Phasenwider. 25/80 °C	Ohm	10.3/12.5	10.3/12.5
Phaseninduktivität	mH	1.4	1.4
Therm. Widerstand	°K/W	7.0	7.0
Therm. Zeitkonstante	sec	1600	1600
Statordurchmesser	mm (in)	23 (0.91)	23 (0.91)
Statorlänge	mm (in)	162 (6.38)	177 (6.97)
Stormasse	g (lb)	265 (0.58)	265 (0.58)
Läuferdurchmesser	mm (in)	12 (0.47)	12 (0.47)
Läuferlänge	mm (in)	580 (22.83)	580 (22.83)
Läufermasse	g (lb)	465 (1.03)	465 (1.03)
Wiederholgenauigkeit	mm (in)	±0.05 (±0.0020)	±0.05 (±0.0020)
Linearität	%	±0.20	±0.20
Wiederholgenauigk. ES	mm (in)	±0.01 (±0.0004)	±0.01 (±0.0004)
Linearität ES	mm (in)	±0.01 (±0.0004)	±0.01 (±0.0004)

## Hub-Zeit Diagramm

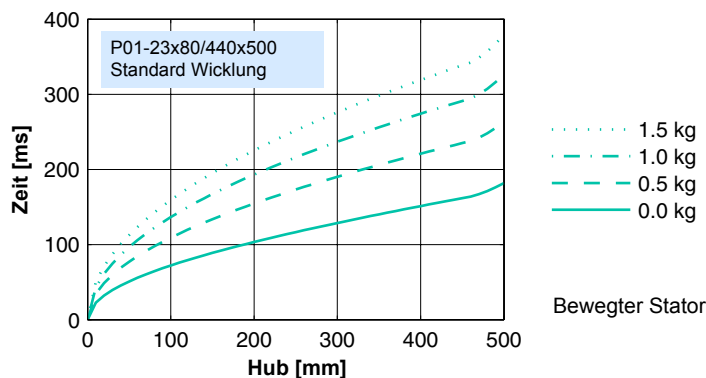

## Stecker Typ

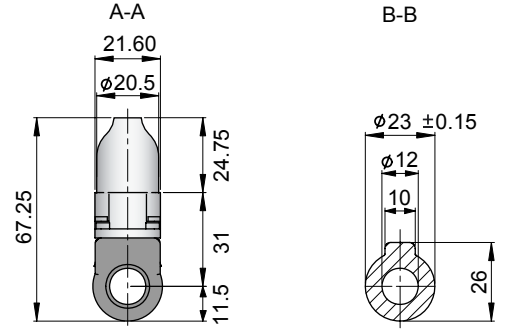
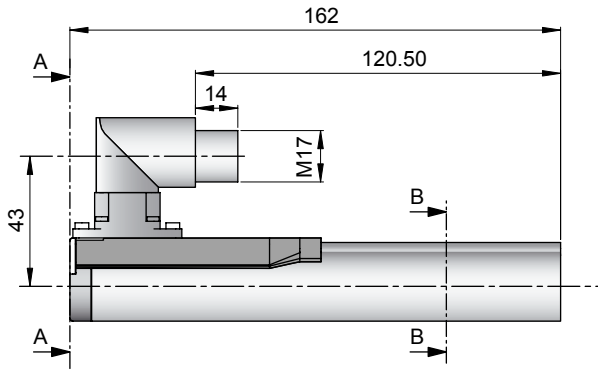

Linearmotor		Stator			Läufer	
Typ	Art. Nr.	Typ	Art. Nr.	Typ	Art. Nr.	
P01-23x80/440x500-R	-->	PS01-23x80-R	0150-1233	&	PL01-12x580/530	0150-1355

## Kabel Typ

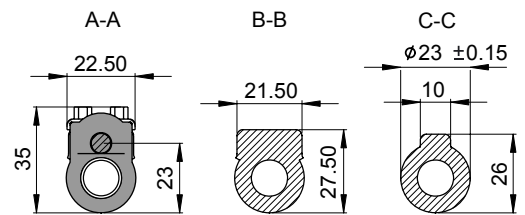
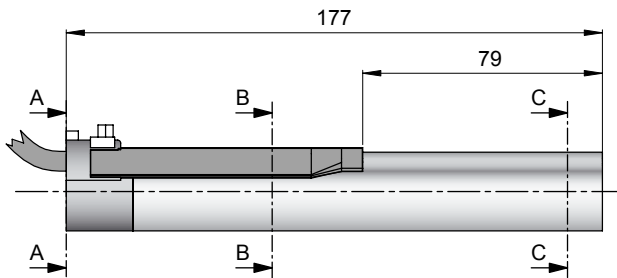

Linearmotor		Stator			Läufer	
Typ	Art. Nr.	Typ	Art. Nr.	Typ	Art. Nr.	
P01-23x80/440x500	-->	PS01-23x80	0150-1201	&	PL01-12x580/530	0150-1355
P01-23x80/440x500-R20	-->	PS01-23x80-R20	0150-1241	&	PL01-12x580/530	0150-1355

## Läufer

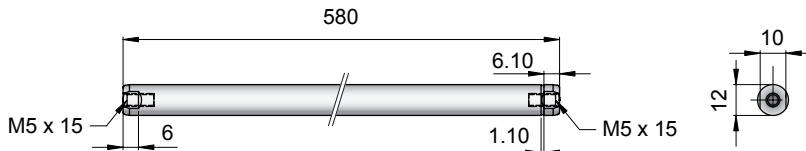

Standard Läufer		Standard Läufer		PL01-12x580/530		0150-1355	
Spezialläufer		Heavy Duty Läufer	mit WC/C-Beschichtung	PL02-12x580/530			0150-1356
		Lochläufer	Innendurchmesser 4.2mm	PL01-12x580/530-L			0150-1391

## Stecker

### Motor Steckerbelegung

Kabellänge:  
P01-23x80/...x... 1.0m  
P01-23x80/...x...-R20 0.2m

		P01-23...-R	P01-23...-R20	P01-23...-R20
Ph 1+	rot	1	1	
Ph 1-	pink	2	6	
Ph 2+	blau	3	2	
Ph 2-	grau	4	7	
+5VDC	weiss	A	3	
GND	innerer Schirm	B	8	
Sinus	gelb	C	4	
Cosinus	grün	D	9	
Temp.	schwarz	E	5	
Schirm	äusserer Schi.	Geh.	Geh.	

## Zubehör

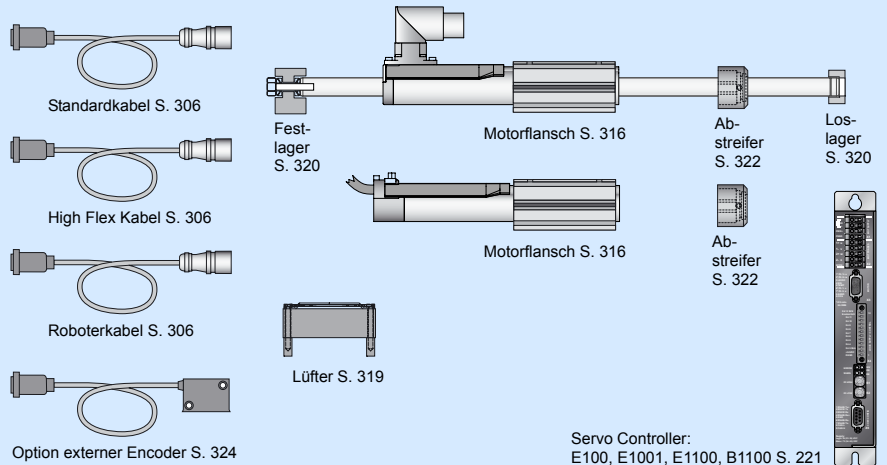

**Maximaler Hub: 680mm**  
**Spitzenkraft: 44N**

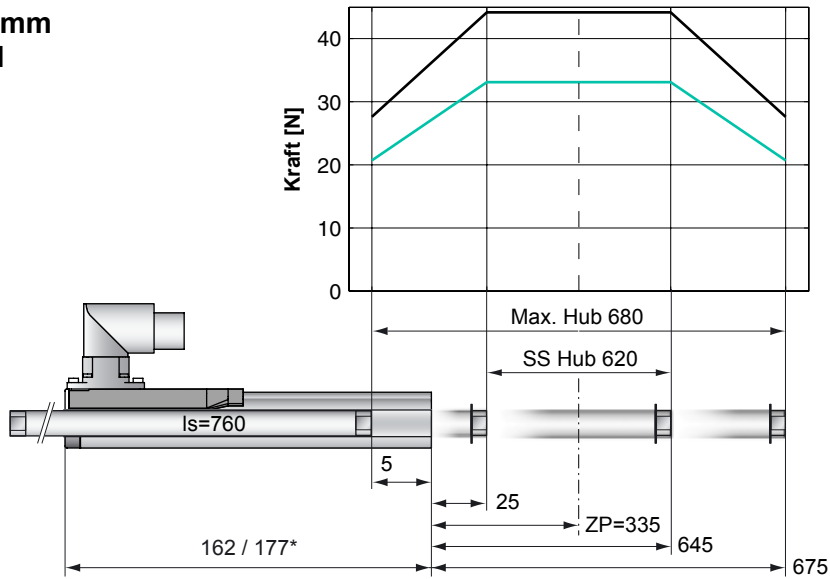

**Standard Wicklung:**

- E1100, 72VDC & E1001, 72VDC
- E100, 48VDC

Abmessungen mm  
 \*Kabel Typ

## Motor Spezifikation

P01-		Stecker Typ	Kabel Typ
		23x80/620x680-R	23x80/620x680 23x80/620x680-R20
Maximaler Hub	mm (in)	680 (26.77)	680 (26.77)
Kurzhubbereich SS	mm (in)	620 (24.41)	620 (24.41)
Spitzenkraft E1100 / E1001	N (lbf)	44 (9.9)	44 (9.9)
Spitzenkraft E100	N (lbf)	33 (7.4)	33 (7.4)
Kont. Kraft	N (lbf)	9 (2.0)	9 (2.0)
Kont. Kraft mit Lüfter	N (lbf)	16 (3.7)	16 (3.7)
Randkraft	%	63	63
Kraftkonstante	N/A (lbf/A)	11.0 (2.48)	11.0 (2.48)
Max. Strom @ 72VDC	A	4.0	4.0
Max. Strom @ 48VDC	A	3.8	3.8
Max. Gesch. @ 72VDC	m/s (in/s)	6.0 (236)	6.0 (236)
Max. Gesch. @ 48VDC	m/s (in/s)	4.0 (157)	4.0 (157)
Phasenwider. 25/80 °C	Ohm	10.3/12.5	10.3/12.5
Phaseninduktivität	mH	1.4	1.4
Therm. Widerstand	°K/W	7.0	7.0
Therm. Zeitkonstante	sec	1600	1600
Statordurchmesser	mm (in)	23 (0.91)	23 (0.91)
Statorlänge	mm (in)	162 (6.38)	177 (6.97)
Stormasse	g (lb)	265 (0.58)	265 (0.58)
Läuferdurchmesser	mm (in)	12 (0.47)	12 (0.47)
Läuferlänge	mm (in)	760 (29.92)	760 (29.92)
Läufermasse	g (lb)	615 (1.36)	615 (1.36)
Wiederholgenauigkeit	mm (in)	±0.05 (±0.0020)	±0.05 (±0.0020)
Linearität	%	±0.20	±0.20
Wiederholgenauigk. ES	mm (in)	±0.01 (±0.0004)	±0.01 (±0.0004)
Linearität ES	mm (in)	±0.01 (±0.0004)	±0.01 (±0.0004)

## Hub-Zeit Diagramm

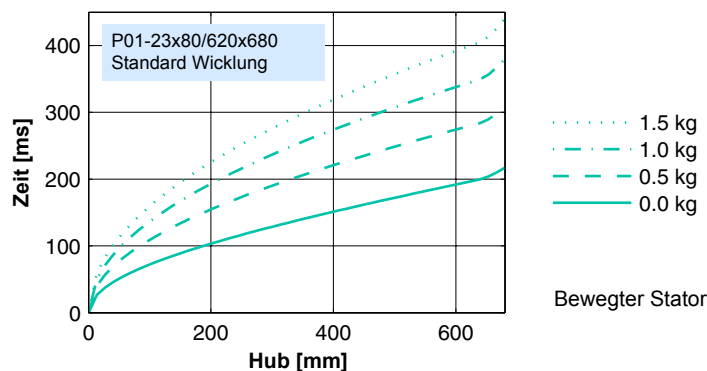

## Stecker Typ

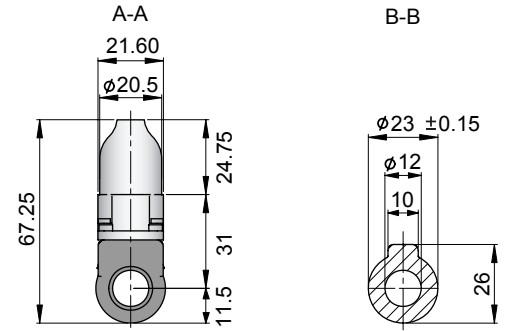
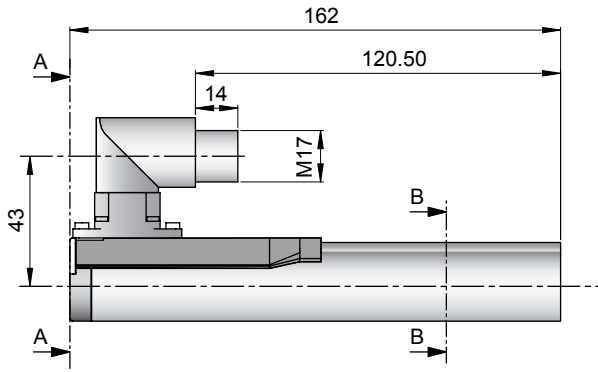

Linearmotor		Stator		Läufer	
Typ	Art. Nr.	Typ	Art. Nr.	Typ	Art. Nr.
P01-23x80/620x680-R	-->	PS01-23x80-R	0150-1233	& PL01-12x760/710	0150-1366

## Kabel Typ

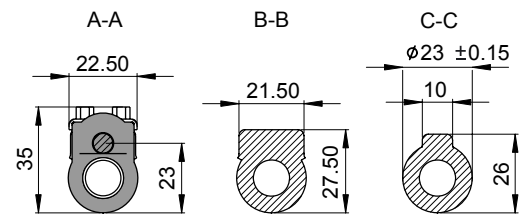
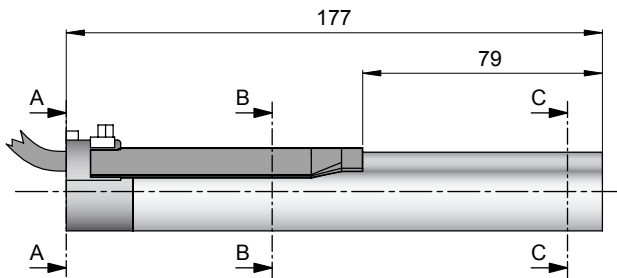

Linearmotor		Stator		Läufer	
Typ	Art. Nr.	Typ	Art. Nr.	Typ	Art. Nr.
P01-23x80/620x680	-->	PS01-23x80	0150-1201	& PL01-12x760/710	0150-1366
P01-23x80/620x680-R20	-->	PS01-23x80-R20	0150-1241	& PL01-12x760/710	0150-1366

## Läufer

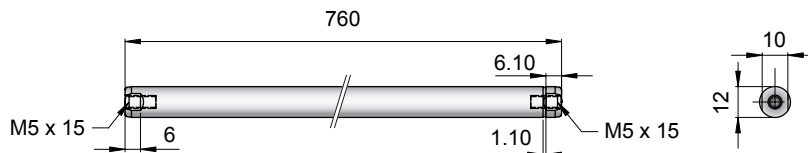

Standard Läufer		Standard Läufer		Läufer	
Typ	Art. Nr.	Typ	Art. Nr.	Typ	Art. Nr.
Standard Läufer		Standard Läufer		PL01-12x760/710	0150-1366
Spezialläufer		Heavy Duty Läufer mit WC/C-Beschichtung		PL02-12x760/710	auf Anfrage
		Lochläufer	Innendurchmesser 4.2mm	PL01-12x760/710-L	0150-1392

## Stecker

### Motor Steckerbelegung

#### Kabellänge:

P01-23x80/...x... 1.0m  
P01-23x80/...x...-R20 0.2m

P01-23...-R  
P01-23...-R20

P01-23...  
P01-23...-R20

Ph	Farbe	1	2
Ph 1+	rot	1	1
Ph 1-	pink	2	6
Ph 2+	blau	3	2
Ph 2-	grau	4	7
+5VDC	weiss	A	3
GND	innerer Schirm	B	8
Sinus	gelb	C	4
Cosinus	grün	D	9
Temp.	schwarz	E	5
Schirm	äusserer Schi.	Geh.	Geh.

## Zubehör

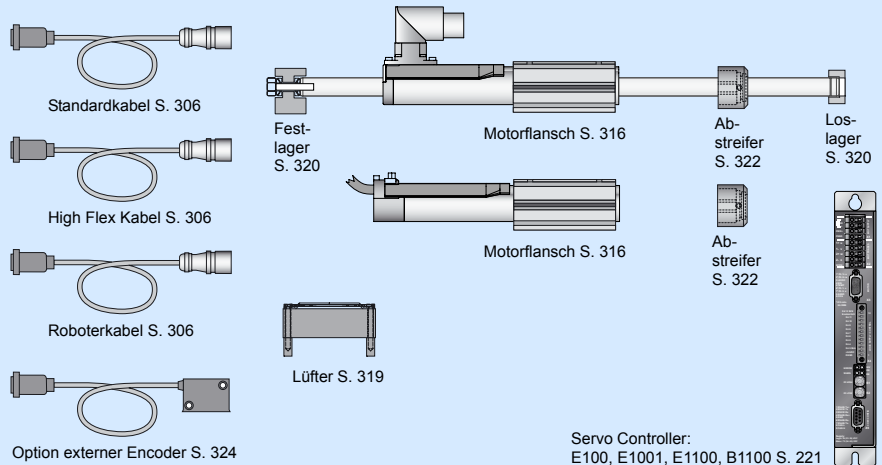

**Maximaler Hub: 770mm**  
**Spitzenkraft: 44N**

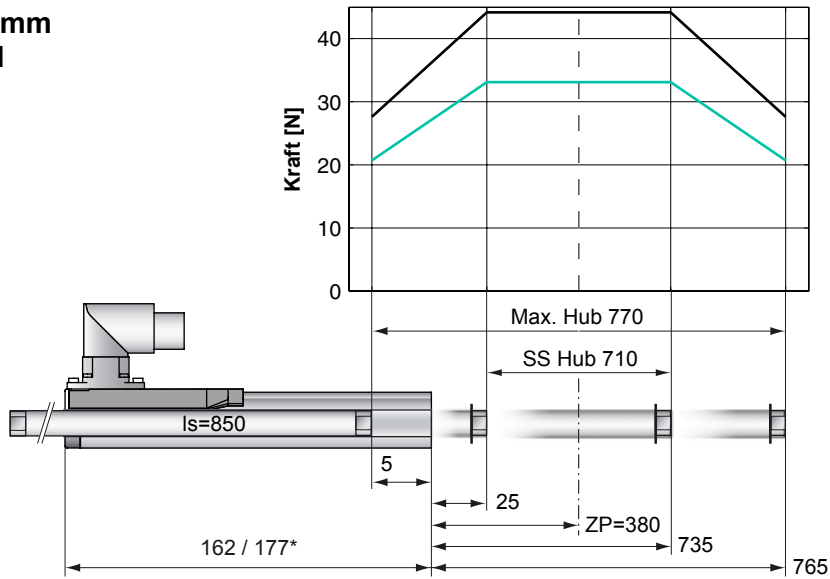

**Standard Wicklung:**

- E1100, 72VDC & E1001, 72VDC
- E100, 48VDC

Abmessungen mm  
 \*Kabel Typ

## Motor Spezifikation

P01-		Stecker Typ	Kabel Typ
		23x80/710x770-R	23x80/710x770 23x80/710x770-R20
Maximaler Hub	mm (in)	770 (30.31)	770 (30.31)
Kurzhubbereich SS	mm (in)	710 (27.95)	710 (27.95)
Spitzenkraft E1100 / E1001	N (lbf)	44 (9.9)	44 (9.9)
Spitzenkraft E100	N (lbf)	33 (7.4)	33 (7.4)
Kont. Kraft	N (lbf)	9 (2.0)	9 (2.0)
Kont. Kraft mit Lüfter	N (lbf)	16 (3.7)	16 (3.7)
Randkraft	%	63	63
Kraftkonstante	N/A (lbf/A)	11.0 (2.48)	11.0 (2.48)
Max. Strom @ 72VDC	A	4.0	4.0
Max. Strom @ 48VDC	A	3.8	3.8
Max. Gesch. @ 72VDC	m/s (in/s)	6.0 (236)	6.0 (236)
Max. Gesch. @ 48VDC	m/s (in/s)	4.0 (157)	4.0 (157)
Phasenwider. 25/80 °C	Ohm	10.3/12.5	10.3/12.5
Phaseninduktivität	mH	1.4	1.4
Therm. Widerstand	°K/W	7.0	7.0
Therm. Zeitkonstante	sec	1600	1600
Statordurchmesser	mm (in)	23 (0.91)	23 (0.91)
Statorlänge	mm (in)	162 (6.38)	177 (6.97)
Stormasse	g (lb)	265 (0.58)	265 (0.58)
Läuferdurchmesser	mm (in)	12 (0.47)	12 (0.47)
Läuferlänge	mm (in)	850 (33.46)	850 (33.46)
Läufermasse	g (lb)	690 (1.52)	690 (1.52)
Wiederholgenauigkeit	mm (in)	±0.05 (±0.0020)	±0.05 (±0.0020)
Linearität	%	±0.20	±0.20
Wiederholgenauigk. ES	mm (in)	±0.01 (±0.0004)	±0.01 (±0.0004)
Linearität ES	mm (in)	±0.01 (±0.0004)	±0.01 (±0.0004)

## Hub-Zeit Diagramm

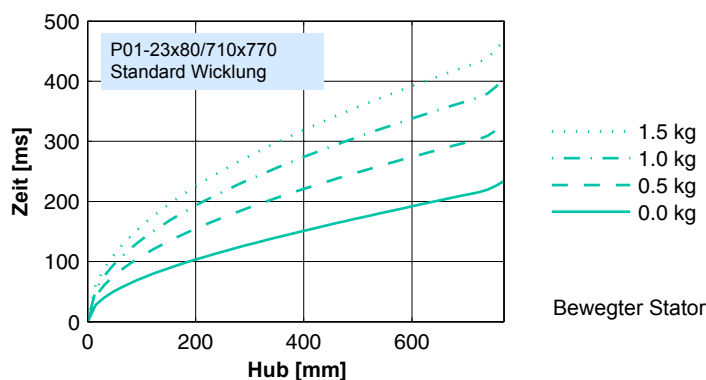

## Stecker Typ

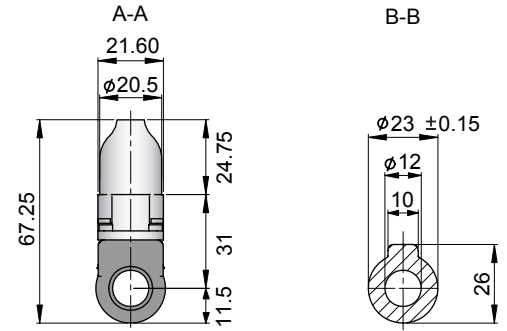
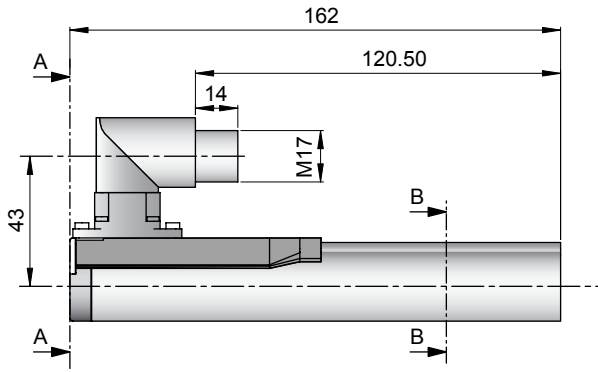

Linearmotor		Stator			Läufer	
Typ	Art. Nr.	Typ	Art. Nr.	Typ	Art. Nr.	
P01-23x80/710x770-R	-->	PS01-23x80-R	0150-1233	&	PL01-12x850/800	0150-1365

## Kabel Typ

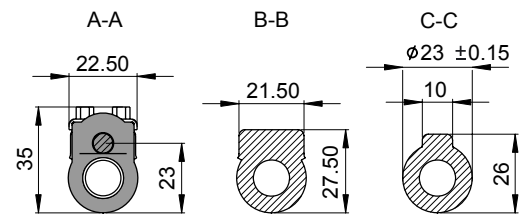
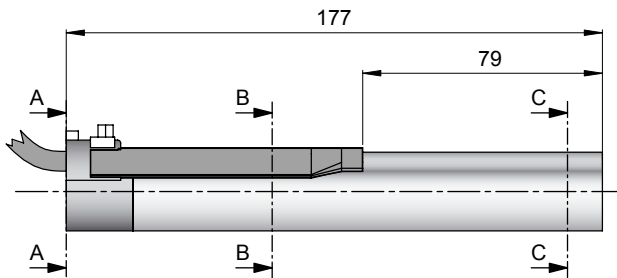

Linearmotor		Stator			Läufer	
Typ	Art. Nr.	Typ	Art. Nr.	Typ	Art. Nr.	
P01-23x80/710x770	-->	PS01-23x80	0150-1201	&	PL01-12x850/800	0150-1365
P01-23x80/710x770-R20	-->	PS01-23x80-R20	0150-1241	&	PL01-12x850/800	0150-1365

## Läufer

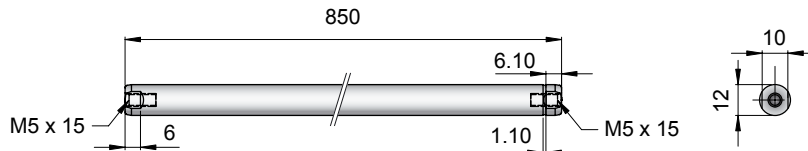

Standard Läufer		Standard Läufer		PL01-12x850/800		0150-1365	
Spezialläufer		Heavy Duty Läufer	mit WC/C-Beschichtung	PL02-12x850/800		auf Anfrage	
		Lochläufer	Innendurchmesser 4.2mm	PL01-12x850/800-L		auf Anfrage	

## Stecker

### Motor Steckerbelegung

#### Kabellänge:

P01-23x80/... 1.0m  
P01-23x80/...-R20 0.2m

P01-23...-R  
P01-23...-R20

P01-23...  
P01-23...-R20

Ph	Farbe	1	2
Ph 1+	rot	1	1
Ph 1-	pink	2	6
Ph 2+	blau	3	2
Ph 2-	grau	4	7
+5VDC	weiss	A	3
GND	innerer Schirm	B	8
Sinus	gelb	C	4
Cosinus	grün	D	9
Temp.	schwarz	E	5
Schirm	äusserer Schi.	Geh.	Geh.

## Zubehör

