



**P01-48x240/30x180 158**

**P01-48x240/90x240 160**

**P01-48x240/180x330 162**

**P01-48x240/300x450 164**

**P01-48x240/390x540 166**

**P01-48x240/480x630 168**

**P01-48x240/600x750 170**

**P01-48x240/690x840 172**

**P01-48x240/900x1050 174**

**P01-48x240/1080x1230 176**

**P01-48x240/1290x1440 178**

**P01-48x240/1500x1650 180**

**P01-48x240/1680x1830 182**

**Maximaler Hub: 180mm**  
**Spitzenkraft: 585N**

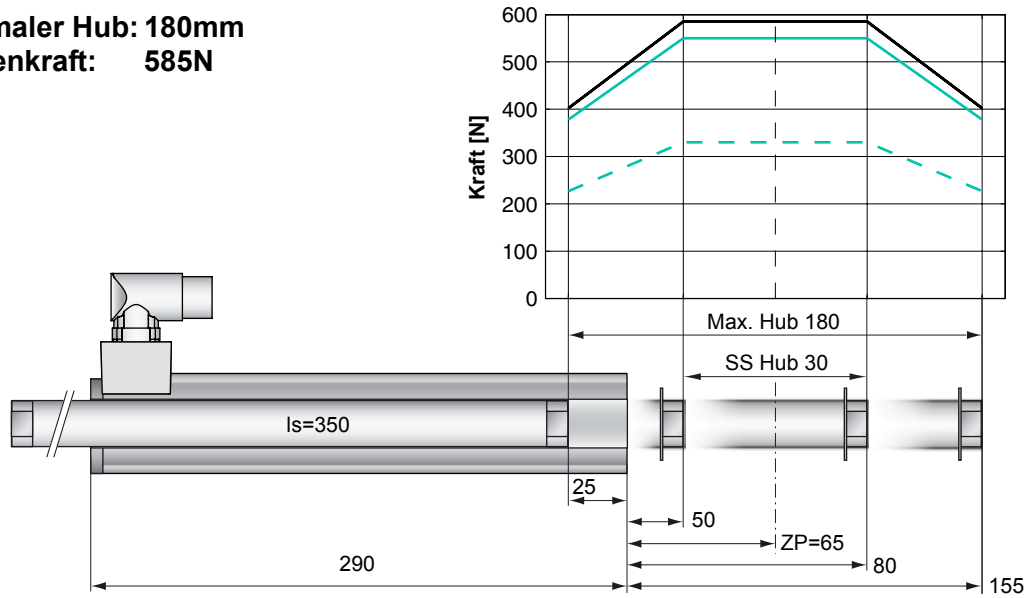

**Standard Wicklung:**  
 — E1100-XC, 72VDC  
 — E1100-HC, 72VDC

**F - Wicklung**  
 — E1100-XC, 72VDC  
 - - E1100-HC, 72VDC

Abmessungen mm

## Motor Spezifikation

P01-		Standard Wicklung	F- Wicklung
		48x240/30x180-C	48x240F/30x180-C
Maximaler Hub	mm (in)	180 (7.09)	180 (7.09)
Kurzhubbereich SS	mm (in)	30 (1.18)	30 (1.18)
Spitzenkraft E1100-XC	N (lbf)	585 (131.5)	550 (123.6)
Spitzenkraft E1100-HC	N (lbf)	585 (131.5)	330 (74.2)
Kont. Kraft	N (lbf)	145 (32.5)	145 (32.6)
Kont. Kraft mit Lüfter	N (lbf)	258 (58.0)	255 (57.3)
Randkraft	%	69	69
Kraftkonstante	N/A (lbf/A)	39.0 (8.77)	22.0 (4.95)
Max. Strom @ 72VDC	A	15.0	26.0
Max. Strom @ 48VDC	A	12.7	26.0
Max. Gesch. @ 72VDC	m/s (in/s)	1.7 (67)	3.0 (119)
Max. Gesch. @ 48VDC	m/s (in/s)	1.1 (45)	2.0 (79)
Phasenwider. 25/80 °C	Ohm	3.1/3.7	1.0/1.2
Phaseninduktivität	mH	3.1	1.0
Therm. Widerstand	°K/W	1.1	1.1
Therm. Zeitkonstante	sec	3000	3000
Stator Durchmesser	mm (in)	48 (1.89)	48 (1.89)
Statorlänge	mm (in)	290 (11.40)	290 (11.40)
Statormasse	g (lb)	1930 (4.25)	1930 (4.25)
Läufer Durchmesser	mm (in)	28 (1.10)	28 (1.10)
Läuferlänge	mm (in)	350 (13.78)	350 (13.78)
Läufermasse	g (lb)	1460 (3.22)	1460 (3.22)
Wiederholgenauigkeit	mm (in)	±0.05 (±0.0020)	±0.05 (±0.0020)
Linearität	%	±0.25	±0.25
Wiederholgenauigk. ES	mm (in)	±0.01 (±0.0004)	±0.01 (±0.0004)
Linearität ES	mm (in)	±0.01 (±0.0004)	±0.01 (±0.0004)

## Hub-Zeit Diagramm

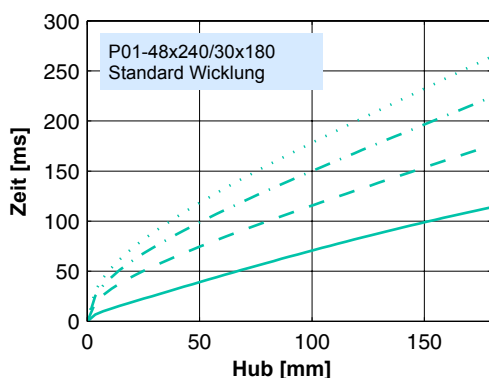

Bewegter Läufer

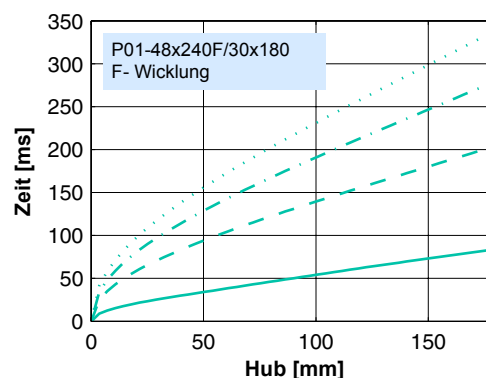

Bewegter Läufer

## Stecker Typ

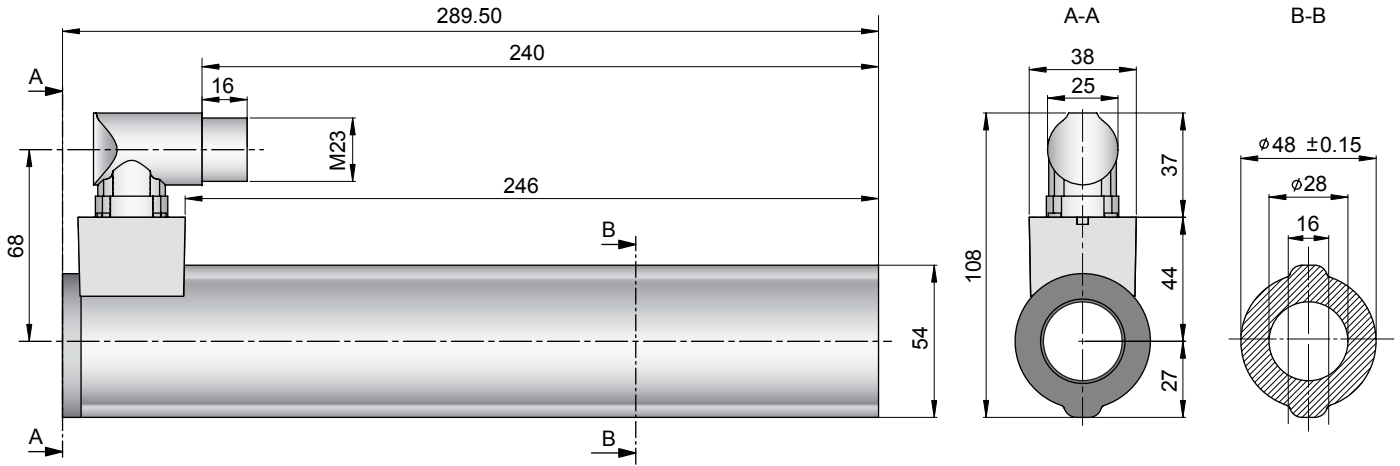

Linearmotor		Stator		Läufer		
Typ	Art. Nr.	Typ	Art. Nr.	Typ	Art. Nr.	
P01-48x240/30x180-C	-->	PS01-48x240-C	0150-1219	&	PL01-28x350/270	0150-1380
P01-48x240F/30x180-C	-->	PS01-48x240F-C	0150-1220	&	PL01-28x350/270	0150-1380

P01-48x240/30x180

## Läufer

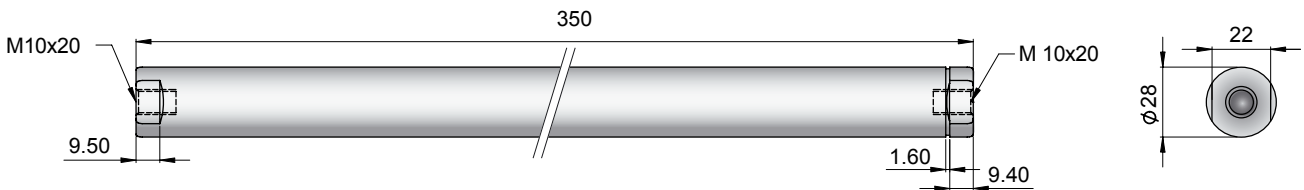

Standard Läufer	Standard Läufer	PL01-28x350/270	0150-1380
Spezialläufer	Heavy Duty Läufer mit WC/C-Beschichtung	PL02-28x350/270	0150-1411
	Lochläufer Innendurchmesser 8.5mm	PL01-28x350/270-L	0150-1475
	High Clearance Läufer d=27mm, m=1360g	PL01-27x350/270	0150-1467

## Stecker

### Motor Steckerbelegung

Motor Steckerbelegung		P01-48...-C
Ph 1+	rot	A
Ph 1-	pink	B
Ph 2+	blau	C
Ph 2-	grau	D
+5VDC	weiss	E
GND	innerer Schirm	F
Sinus	gelb	G
Cosinus	grün	H
Temp.	schwarz	L
Schirm	äusserer Schi.	Geh.

## Zubehör

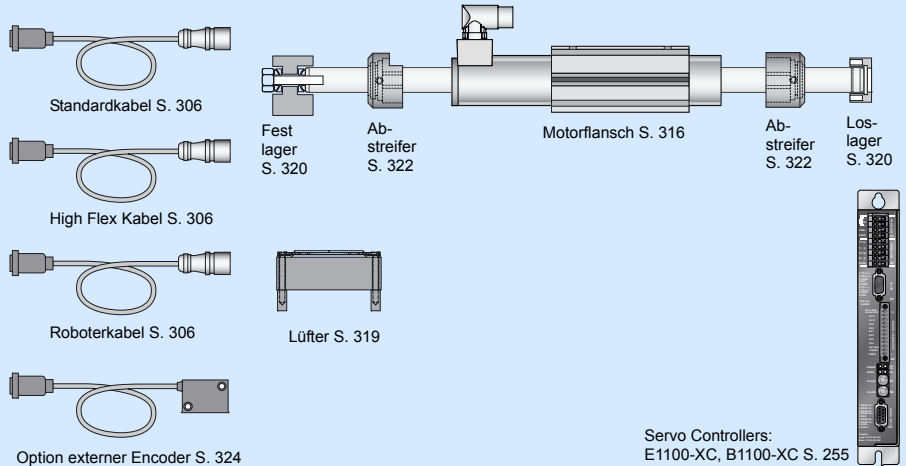

**Maximaler Hub: 240mm**  
**Spitzenkraft: 585N**

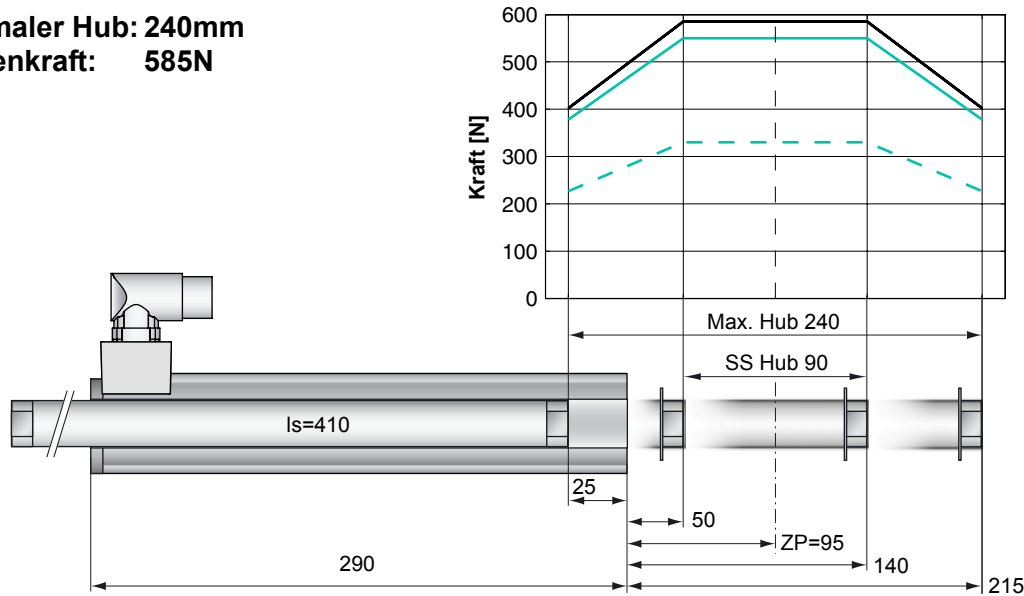

**Standard Wicklung:**  
 — E1100-XC, 72VDC  
 — E1100-HC, 72VDC

**F - Wicklung**  
 — E1100-XC, 72VDC  
 - - - E1100-HC, 72VDC

Abmessungen mm

## Motor Spezifikation

P01-		Standard Wicklung	F- Wicklung
		48x240/90x240-C	48x240F/90x240-C
Maximaler Hub	mm (in)	240 (9.45)	240 (9.45)
Kurzhubbereich SS	mm (in)	90 (3.54)	90 (3.54)
Spitzenkraft E1100-XC	N (lbf)	585 (131.5)	550 (123.6)
Spitzenkraft E1100-HC	N (lbf)	585 (131.5)	330 (74.2)
Kont. Kraft	N (lbf)	145 (32.5)	145 (32.6)
Kont. Kraft mit Lüfter	N (lbf)	258 (58.0)	255 (57.3)
Randkraft	%	69	69
Kraftkonstante	N/A (lbf/A)	39.0 (8.77)	22.0 (4.95)
Max. Strom @ 72VDC	A	15.0	26.0
Max. Strom @ 48VDC	A	12.7	26.0
Max. Gesch. @ 72VDC	m/s (in/s)	1.7 (67)	3.0 (119)
Max. Gesch. @ 48VDC	m/s (in/s)	1.1 (45)	2.0 (79)
Phasenwider. 25/80 °C	Ohm	3.1/3.7	1.0/1.2
Phaseninduktivität	mH	3.1	1.0
Therm. Widerstand	°K/W	1.1	1.1
Therm. Zeitkonstante	sec	3000	3000
Statordurchmesser	mm (in)	48 (1.89)	48 (1.89)
Statorlänge	mm (in)	290 (11.40)	290 (11.40)
Statormasse	g (lb)	1930 (4.25)	1930 (4.25)
Läuferdurchmesser	mm (in)	28 (1.10)	28 (1.10)
Läuferlänge	mm (in)	410 (16.14)	410 (16.14)
Läufermasse	g (lb)	1740 (3.84)	1740 (3.84)
Wiederholgenauigkeit	mm (in)	±0.05 (±0.0020)	±0.05 (±0.0020)
Linearität	%	±0.20	±0.20
Wiederholgenauigk. ES	mm (in)	±0.01 (±0.0004)	±0.01 (±0.0004)
Linearität ES	mm (in)	±0.01 (±0.0004)	±0.01 (±0.0004)

## Hub-Zeit Diagramm

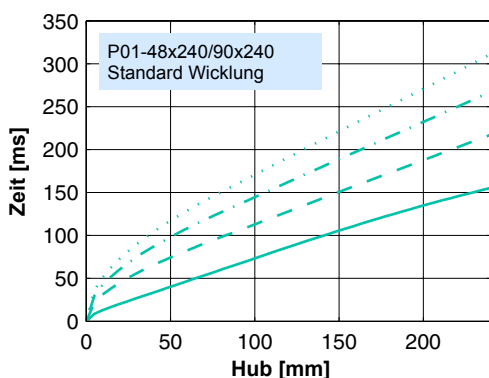

Bewegter Läufer

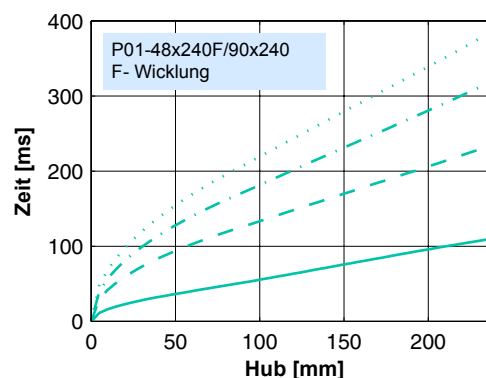

Bewegter Läufer

## Stecker Typ

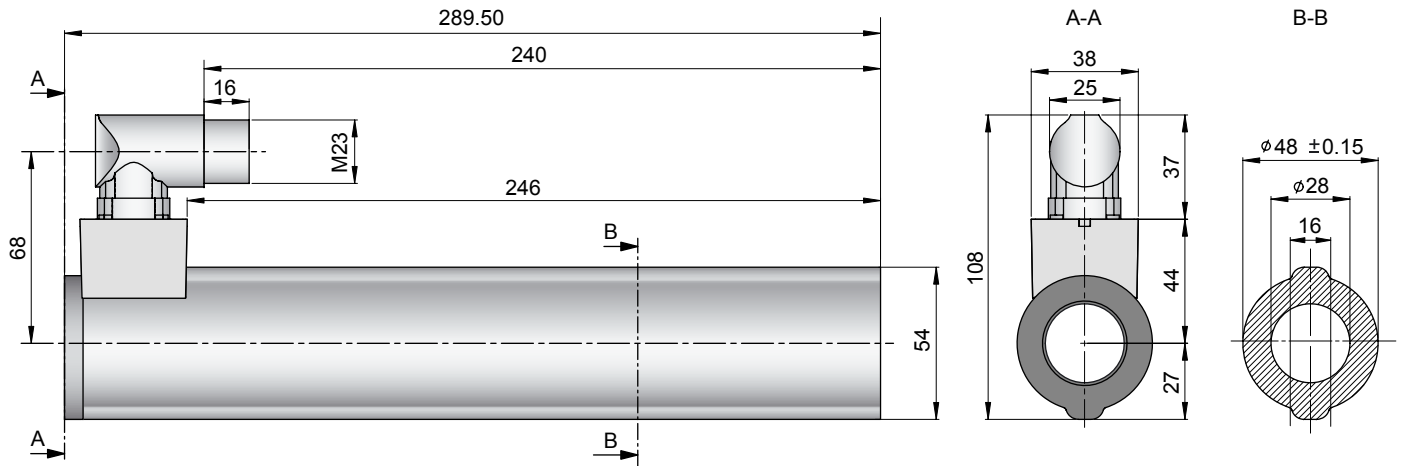

Linearmotor		Stator		Läufer		
Typ	Art. Nr.	Typ	Art. Nr.	Typ	Art. Nr.	
P01-48x240/90x240-C	-->	PS01-48x240-C	0150-1219	&	PL01-28x410/330	0150-1381
P01-48x240F/90x240-C	-->	PS01-48x240F-C	0150-1220	&	PL01-28x410/330	0150-1381

P01-48x240/90x240

## Läufer

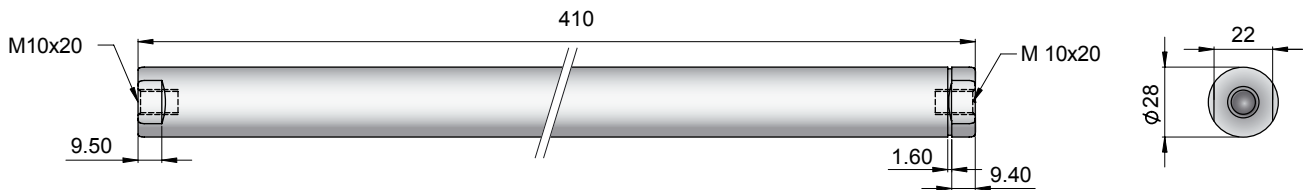

Standard Läufer	Standard Läufer	PL01-28x410/330	0150-1381
Spezialläufer	Heavy Duty Läufer mit WC/C-Beschichtung	PL02-28x410/330	0150-1412
	Lochläufer Innendurchmesser 8.5mm	PL01-28x410/330-L	0150-1476
	High Clearance Läufer d=27mm, m=1620g	PL01-27x410/330	0150-1468

## Stecker

### Motor Steckerbelegung

Motor Steckerbelegung		P01-48...-C
Ph 1+	rot	A
Ph 1-	pink	B
Ph 2+	blau	C
Ph 2-	grau	D
+5VDC	weiss	E
GND	innerer Schirm	F
Sinus	gelb	G
Cosinus	grün	H
Temp.	schwarz	L
Schirm	äusserer Schi.	Geh.

## Zubehör

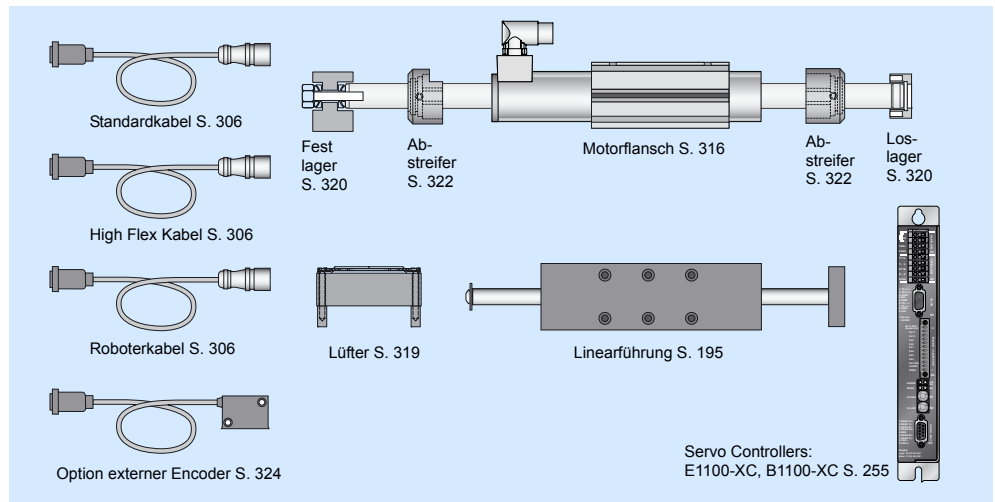

**Maximaler Hub: 330mm**  
**Spitzenkraft: 585N**

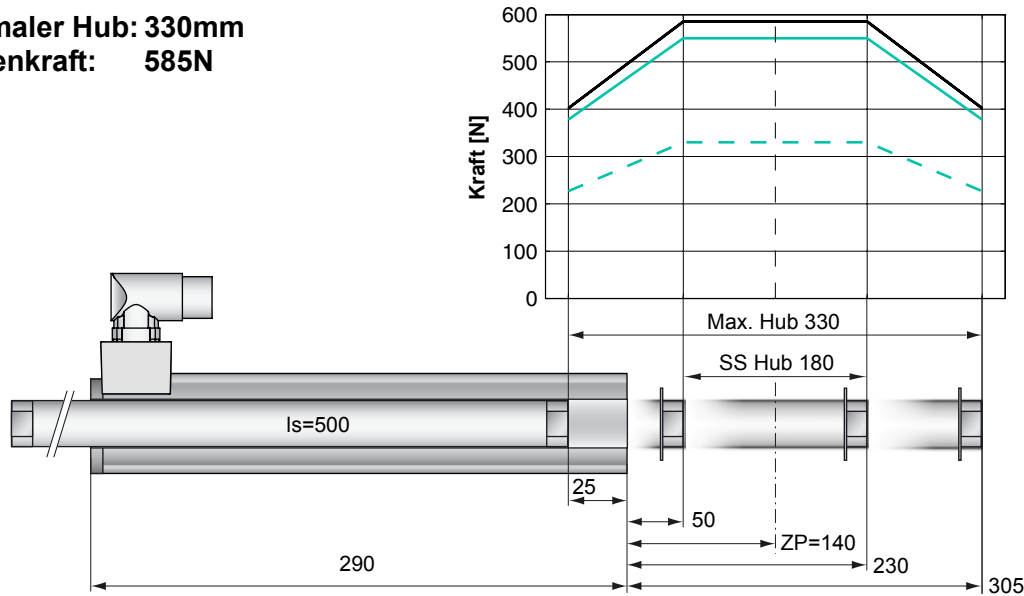

**Standard Wicklung:**  
 — E1100-XC, 72VDC  
 — E1100-HC, 72VDC

**F - Wicklung**  
 — E1100-XC, 72VDC  
 - - - E1100-HC, 72VDC

Abmessungen mm

## Motor Spezifikation

P01-		Standard Wicklung	F- Wicklung
		48x240/180x330-C	48x240F/180x330-C
Maximaler Hub	mm (in)	330 (12.99)	330 (12.99)
Kurzhubbereich SS	mm (in)	180 (7.09)	180 (7.09)
Spitzenkraft E1100-XC	N (lbf)	585 (131.5)	550 (123.6)
Spitzenkraft E1100-HC	N (lbf)	585 (131.5)	330 (74.2)
Kont. Kraft	N (lbf)	145 (32.5)	145 (32.6)
Kont. Kraft mit Lüfter	N (lbf)	258 (58.0)	255 (57.3)
Randkraft	%	69	69
Kraftkonstante	N/A (lbf/A)	39.0 (8.77)	22.0 (4.95)
Max. Strom @ 72VDC	A	15.0	26.0
Max. Strom @ 48VDC	A	12.7	26.0
Max. Gesch. @ 72VDC	m/s (in/s)	1.7 (67)	3.0 (119)
Max. Gesch. @ 48VDC	m/s (in/s)	1.1 (45)	2.0 (79)
Phasenwider. 25/80 °C	Ohm	3.1/3.7	1.0/1.2
Phaseninduktivität	mH	3.1	1.0
Therm. Widerstand	°K/W	1.1	1.1
Therm. Zeitkonstante	sec	3000	3000
Statordurchmesser	mm (in)	48 (1.89)	48 (1.89)
Statorlänge	mm (in)	290 (11.40)	290 (11.40)
Statormasse	g (lb)	1930 (4.25)	1930 (4.25)
Läuferdurchmesser	mm (in)	28 (1.10)	28 (1.10)
Läuferlänge	mm (in)	500 (19.69)	500 (19.69)
Läufermasse	g (lb)	2160 (4.76)	2160 (4.76)
Wiederholgenauigkeit	mm (in)	±0.05 (±0.0020)	±0.05 (±0.0020)
Linearität	%	±0.15	±0.15
Wiederholgenauigk. ES	mm (in)	±0.01 (±0.0004)	±0.01 (±0.0004)
Linearität ES	mm (in)	±0.01 (±0.0004)	±0.01 (±0.0004)

## Hub-Zeit Diagramm

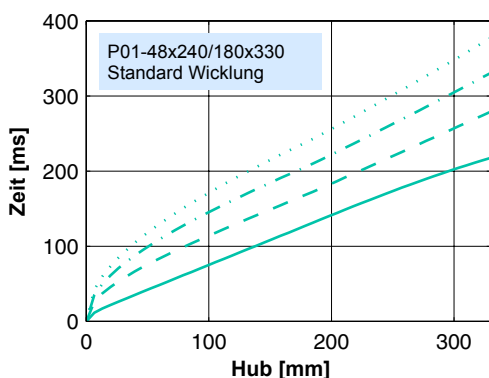

30.0 kg  
 20.0 kg  
 10.0 kg  
 0.0 kg

Bewegter Läufer

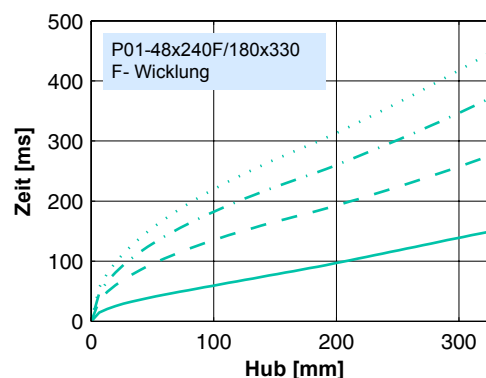

30.0 kg  
 20.0 kg  
 10.0 kg  
 0.0 kg

Bewegter Läufer

## Stecker Typ

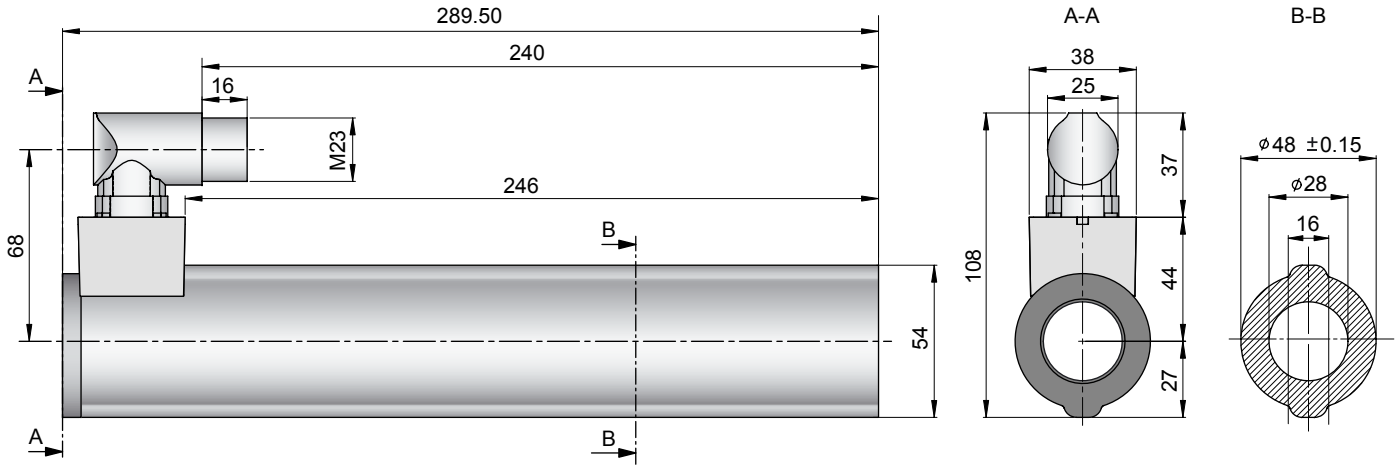

Linearmotor		Stator		Läufer		
Typ	Art. Nr.	Typ	Art. Nr.	&	Typ	Art. Nr.
P01-48x240/180x330-C	-->	PS01-48x240-C	0150-1219	&	PL01-28x500/420	0150-1382
P01-48x240F/180x330-C	-->	PS01-48x240F-C	0150-1220	&	PL01-28x500/420	0150-1382

P01-48x240/180x330

## Läufer

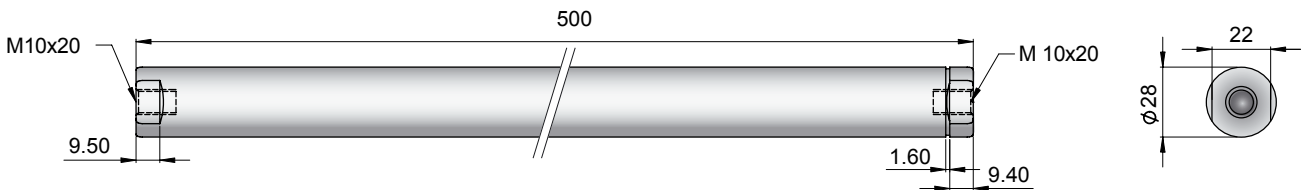

Standard Läufer	Standard Läufer	PL01-28x500/420	0150-1382
Spezialläufer	Heavy Duty Läufer mit WC/C-Beschichtung	PL02-28x500/420	0150-1413
	Lochläufer Innendurchmesser 8.5mm	PL01-28x500/420-L	0150-1480
	High Clearance Läufer d=27mm, m=2010g	PL01-27x500/420	0150-1469

## Stecker

### Motor Steckerbelegung

Motor Steckerbelegung		P01-48...-C
Ph 1+	rot	A
Ph 1-	pink	B
Ph 2+	blau	C
Ph 2-	grau	D
+5VDC	weiss	E
GND	innerer Schirm	F
Sinus	gelb	G
Cosinus	grün	H
Temp.	schwarz	L
Schirm	äusserer Schi.	Geh.

## Zubehör

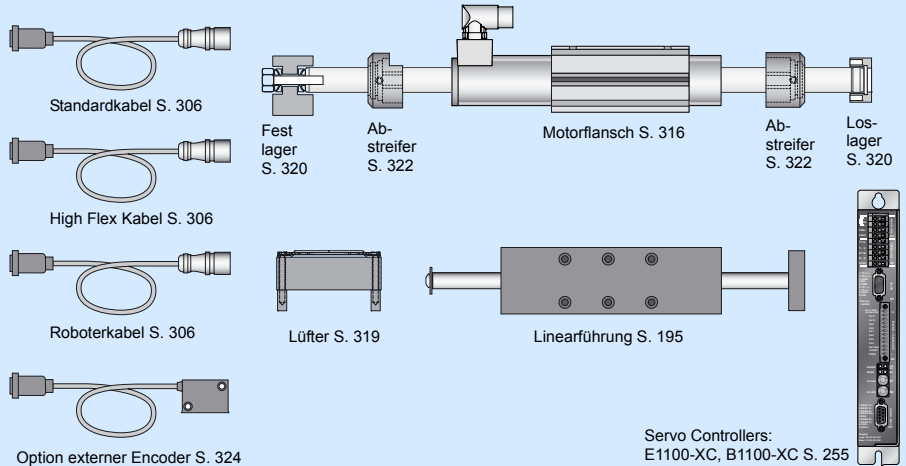

**Maximaler Hub: 450mm**  
**Spitzenkraft: 585N**

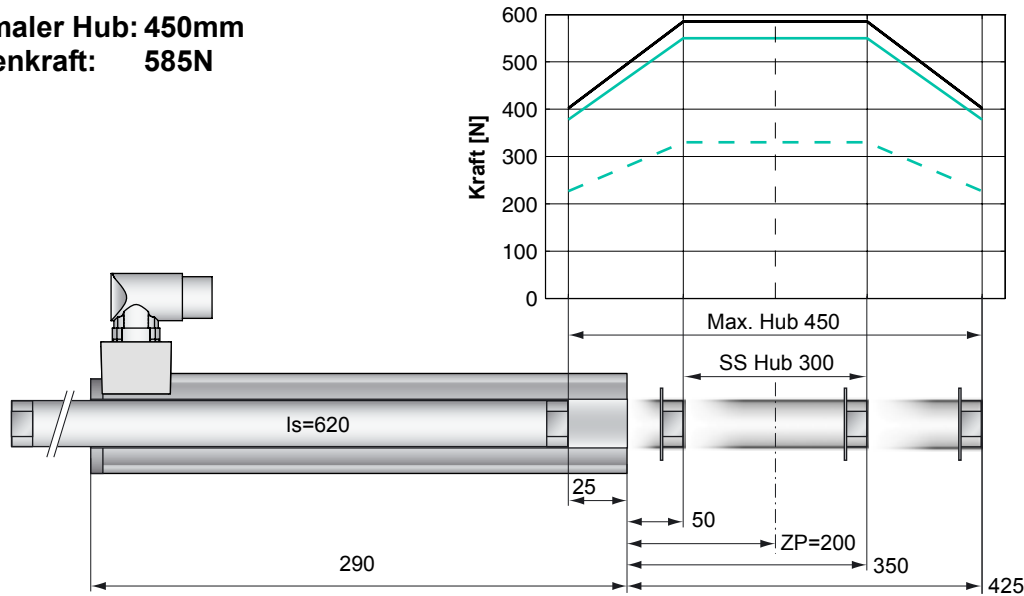

**Standard Wicklung:**  
 — E1100-XC, 72VDC  
 — E1100-HC, 72VDC

**F - Wicklung**  
 — E1100-XC, 72VDC  
 - - E1100-HC, 72VDC

Abmessungen mm

## Motor Spezifikation

P01-		Standard Wicklung	F- Wicklung
		48x240/300x450-C	48x240F/300x450-C
Maximaler Hub	mm (in)	450 (17.72)	450 (17.72)
Kurzhubbereich SS	mm (in)	300 (11.81)	300 (11.81)
Spitzenkraft E1100-XC	N (lbf)	585 (131.5)	550 (123.6)
Spitzenkraft E1100-HC	N (lbf)	585 (131.5)	330 (74.2)
Kont. Kraft	N (lbf)	145 (32.5)	145 (32.6)
Kont. Kraft mit Lüfter	N (lbf)	258 (58.0)	255 (57.3)
Randkraft	%	69	69
Kraftkonstante	N/A (lbf/A)	39.0 (8.77)	22.0 (4.95)
Max. Strom @ 72VDC	A	15.0	26.0
Max. Strom @ 48VDC	A	12.7	26.0
Max. Gesch. @ 72VDC	m/s (in/s)	1.7 (67)	3.0 (119)
Max. Gesch. @ 48VDC	m/s (in/s)	1.1 (45)	2.0 (79)
Phasenwider. 25/80 °C	Ohm	3.1/3.7	1.0/1.2
Phaseninduktivität	mH	3.1	1.0
Therm. Widerstand	°K/W	1.1	1.1
Therm. Zeitkonstante	sec	3000	3000
Statordurchmesser	mm (in)	48 (1.89)	48 (1.89)
Statorlänge	mm (in)	290 (11.40)	290 (11.40)
Statormasse	g (lb)	1930 (4.25)	1930 (4.25)
Läuferdurchmesser	mm (in)	28 (1.10)	28 (1.10)
Läuferlänge	mm (in)	620 (24.41)	620 (24.41)
Läufermasse	g (lb)	2720 (6.00)	2720 (6.00)
Wiederholgenauigkeit	mm (in)	±0.05 (±0.0020)	±0.05 (±0.0020)
Linearität	%	±0.15	±0.15
Wiederholgenauigk. ES	mm (in)	±0.01 (±0.0004)	±0.01 (±0.0004)
Linearität ES	mm (in)	±0.01 (±0.0004)	±0.01 (±0.0004)

## Hub-Zeit Diagramm

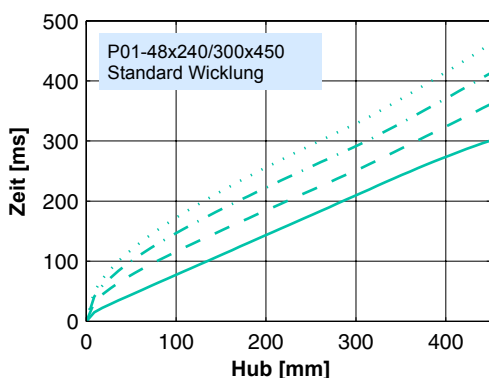

30.0 kg  
 20.0 kg  
 10.0 kg  
 0.0 kg

Bewegter Läufer

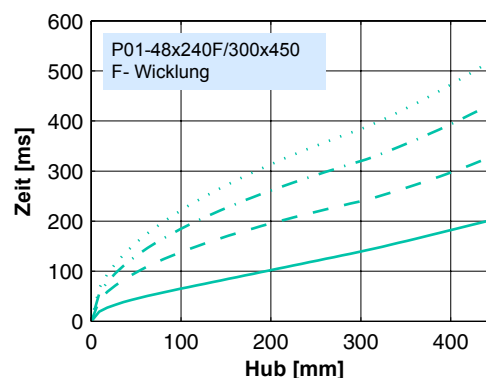

30.0 kg  
 20.0 kg  
 10.0 kg  
 0.0 kg

Bewegter Läufer

## Stecker Typ

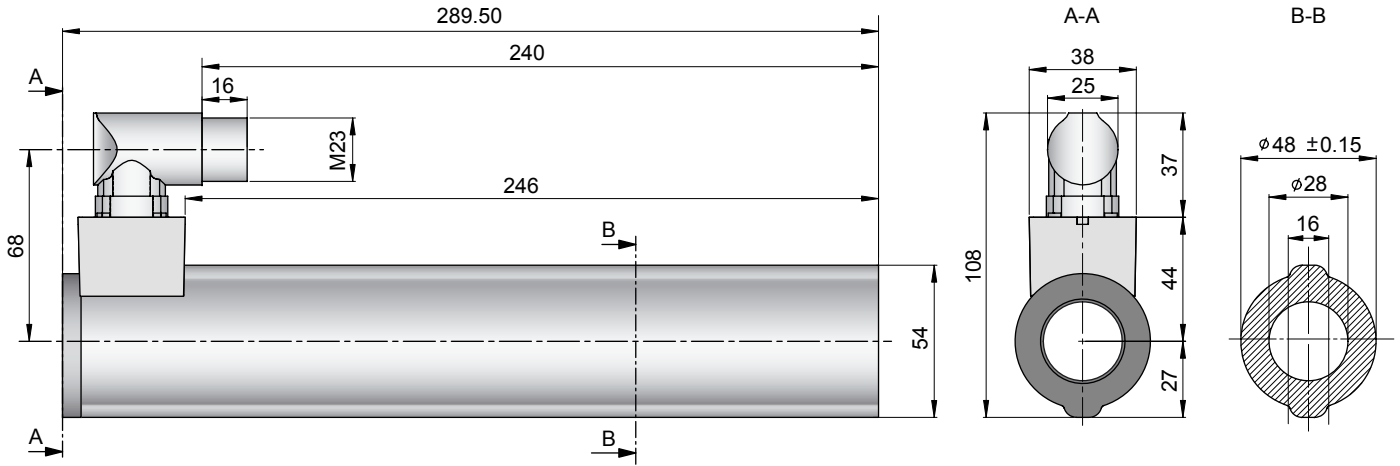

Linearmotor		Stator		Läufer		
Typ	Art. Nr.	Typ	Art. Nr.	&	Typ	Art. Nr.
P01-48x240/300x450-C	-->	PS01-48x240-C	0150-1219	&	PL01-28x620/540	0150-1383
P01-48x240F/300x450-C	-->	PS01-48x240F-C	0150-1220	&	PL01-28x620/540	0150-1383

P01-48x240/300x450

## Läufer

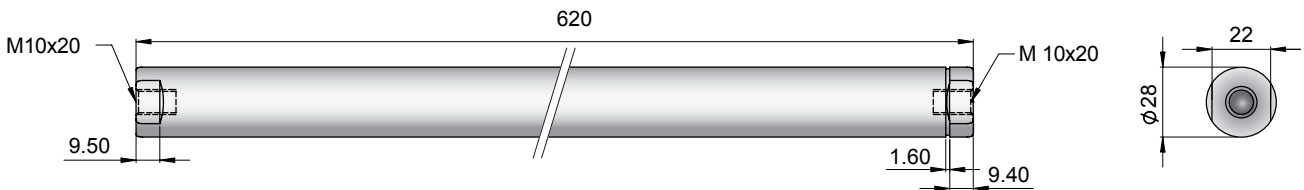

Standard Läufer	Standard Läufer	PL01-28x620/540	0150-1383
Spezialläufer	Heavy Duty Läufer mit WC/C-Beschichtung	PL02-28x620/540	0150-1414
	Lochläufer Innendurchmesser 8.5mm	PL01-28x620/540-L	0150-1481
	High Clearance Läufer d=27mm, m=2530g	PL01-27x620/540	0150-1470

## Stecker

### Motor Steckerbelegung

		P01-48...-C
Ph 1+	rot	A
Ph 1-	pink	B
Ph 2+	blau	C
Ph 2-	grau	D
+5VDC	weiss	E
GND	innerer Schirm	F
Sinus	gelb	G
Cosinus	grün	H
Temp.	schwarz	L
Schirm	äusserer Schi.	Geh.

## Zubehör

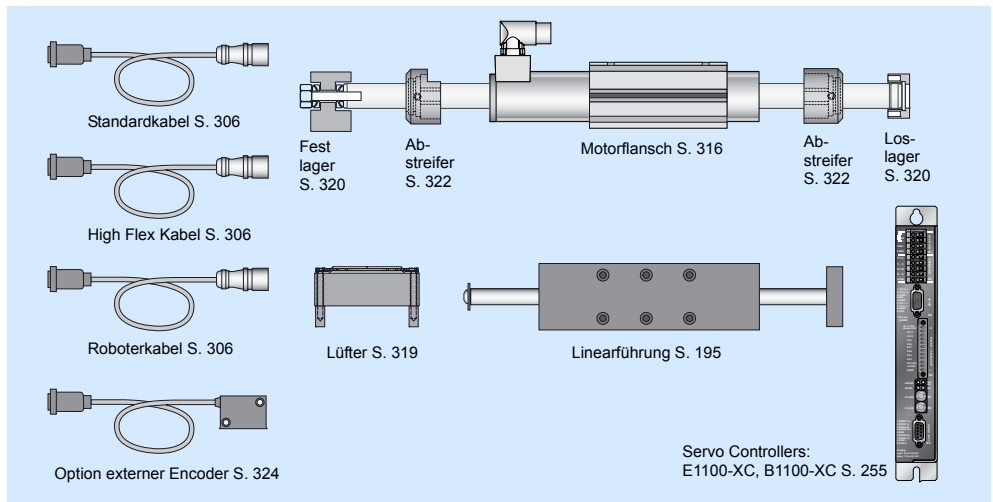

**Maximaler Hub: 540mm**  
**Spitzenkraft: 585N**

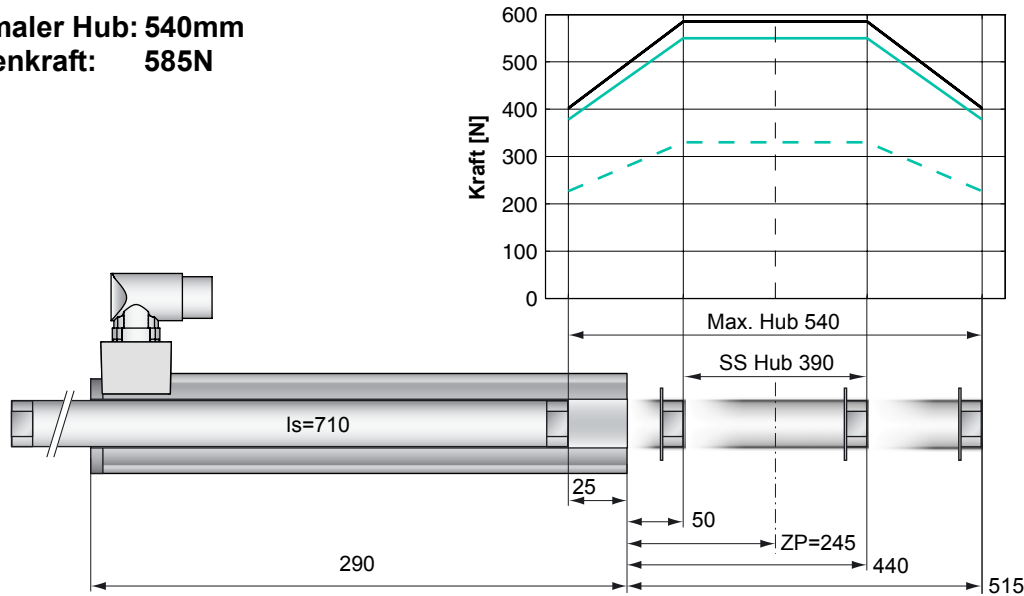

**Standard Wicklung:**  
 — E1100-XC, 72VDC  
 — E1100-HC, 72VDC

**F - Wicklung**  
 — E1100-XC, 72VDC  
 - - E1100-HC, 72VDC

Abmessungen mm

## Motor Spezifikation

P01-		Standard Wicklung	F- Wicklung
		48x240/390x540-C	48x240F/390x540-C
Maximaler Hub	mm (in)	540 (21.26)	540 (21.26)
Kurzhubbereich SS	mm (in)	390 (15.35)	390 (15.35)
Spitzenkraft E1100-XC	N (lbf)	585 (131.5)	550 (123.6)
Spitzenkraft E1100-HC	N (lbf)	585 (131.5)	330 (74.2)
Kont. Kraft	N (lbf)	145 (32.5)	145 (32.6)
Kont. Kraft mit Lüfter	N (lbf)	258 (58.0)	255 (57.3)
Randkraft	%	69	69
Kraftkonstante	N/A (lbf/A)	39.0 (8.77)	22.0 (4.95)
Max. Strom @ 72VDC	A	15.0	26.0
Max. Strom @ 48VDC	A	12.7	26.0
Max. Gesch. @ 72VDC	m/s (in/s)	1.7 (67)	3.0 (119)
Max. Gesch. @ 48VDC	m/s (in/s)	1.1 (45)	2.0 (79)
Phasenwider. 25/80 °C	Ohm	3.1/3.7	1.0/1.2
Phaseninduktivität	mH	3.1	1.0
Therm. Widerstand	°K/W	1.1	1.1
Therm. Zeitkonstante	sec	3000	3000
Statordurchmesser	mm (in)	48 (1.89)	48 (1.89)
Statorlänge	mm (in)	290 (11.40)	290 (11.40)
Statormasse	g (lb)	1930 (4.25)	1930 (4.25)
Läuferdurchmesser	mm (in)	28 (1.10)	28 (1.10)
Läuferlänge	mm (in)	710 (27.95)	710 (27.95)
Läufermasse	g (lb)	3140 (6.92)	3140 (6.92)
Wiederholgenauigkeit	mm (in)	±0.05 (±0.0020)	±0.05 (±0.0020)
Linearität	%	±0.15	±0.15
Wiederholgenauigk. ES	mm (in)	±0.01 (±0.0004)	±0.01 (±0.0004)
Linearität ES	mm (in)	±0.01 (±0.0004)	±0.01 (±0.0004)

## Hub-Zeit Diagramm

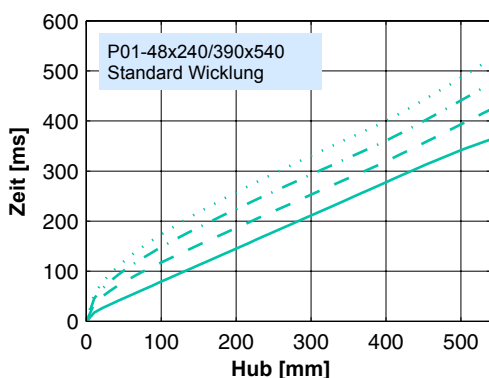

Bewegter Läufer

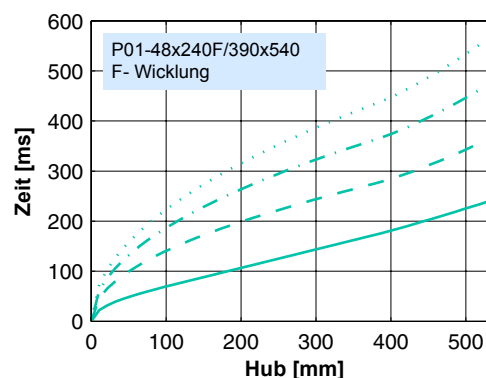

Bewegter Läufer

## Stecker Typ

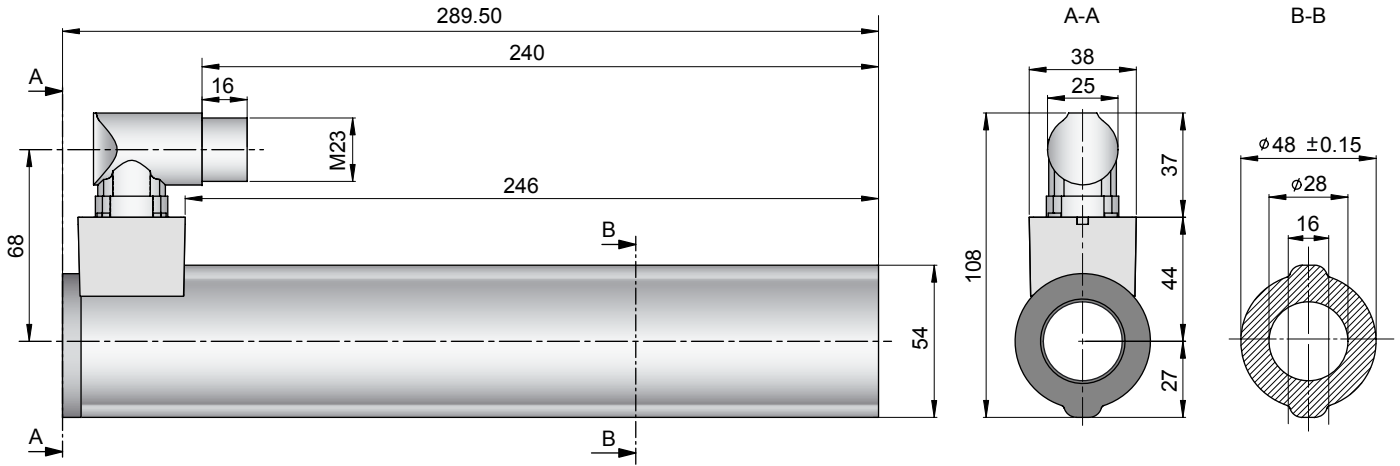

Linearmotor		Stator		Läufer		
Typ	Art. Nr.	Typ	Art. Nr.	Typ	Art. Nr.	
P01-48x240/390x540-C	-->	PS01-48x240-C	0150-1219	&	PL01-28x710/630	0150-1384
P01-48x240F/390x540-C	-->	PS01-48x240F-C	0150-1220	&	PL01-28x710/630	0150-1384

P01-48x240/390x540

## Läufer

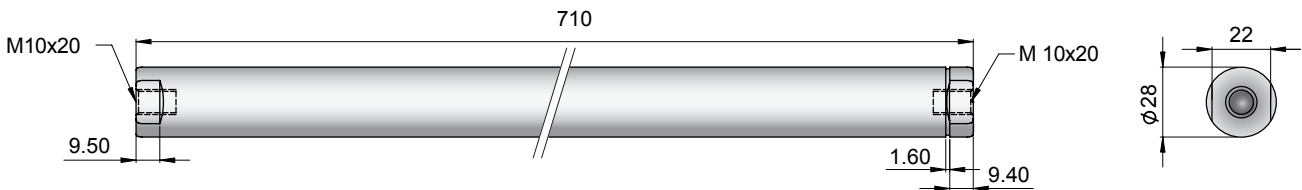

Standard Läufer	Standard Läufer	PL01-28x710/630	0150-1384
Spezialläufer	Heavy Duty Läufer mit WC/C-Beschichtung	PL02-28x710/630	0150-1415
	Lochläufer Innendurchmesser 8.5mm	PL01-28x710/630-L	0150-1482
	High Clearance Läufer d=27mm, m=2920g	PL01-27x710/630	0150-1471

## Stecker

### Motor Steckerbelegung

Motor Steckerbelegung		P01-48...-C
Ph 1+	rot	A
Ph 1-	pink	B
Ph 2+	blau	C
Ph 2-	grau	D
+5VDC	weiss	E
GND	innerer Schirm	F
Sinus	gelb	G
Cosinus	grün	H
Temp.	schwarz	L
Schirm	äusserer Schi.	Geh.

## Zubehör

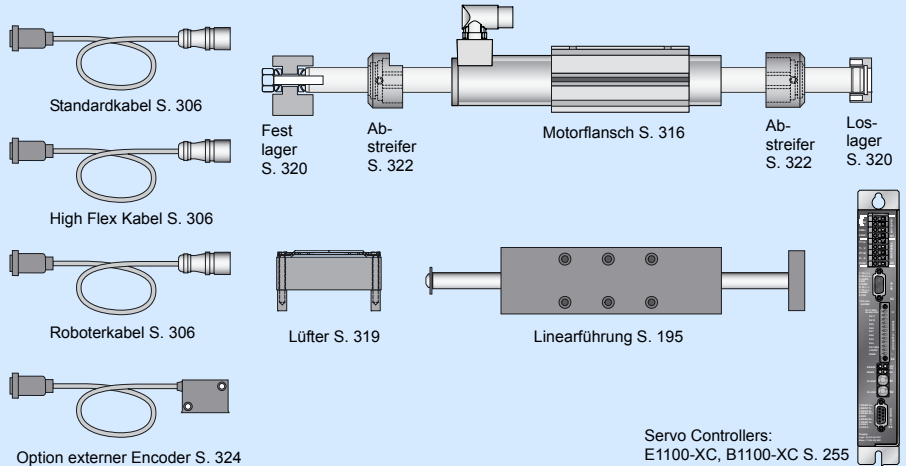

**Maximaler Hub: 630mm**  
**Spitzenkraft: 585N**

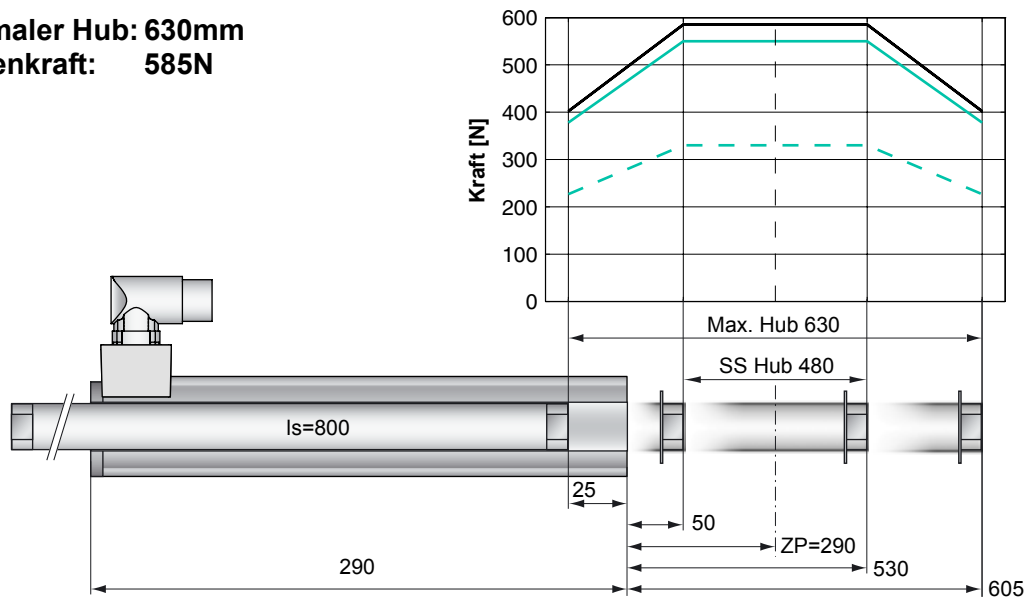

**Standard Wicklung:**  
 — E1100-XC, 72VDC  
 — E1100-HC, 72VDC

**F - Wicklung**  
 — E1100-XC, 72VDC  
 - - E1100-HC, 72VDC

Abmessungen mm

## Motor Spezifikation

P01-		Standard Wicklung	F- Wicklung
		48x240/480x630-C	48x240F/480x630-C
Maximaler Hub	mm (in)	630 (24.80)	630 (24.80)
Kurzhubbereich SS	mm (in)	480 (18.90)	480 (18.90)
Spitzenkraft E1100-XC	N (lbf)	585 (131.5)	550 (123.6)
Spitzenkraft E1100-HC	N (lbf)	585 (131.5)	330 (74.2)
Kont. Kraft	N (lbf)	145 (32.5)	145 (32.6)
Kont. Kraft mit Lüfter	N (lbf)	258 (58.0)	255 (57.3)
Randkraft	%	69	69
Kraftkonstante	N/A (lbf/A)	39.0 (8.77)	22.0 (4.95)
Max. Strom @ 72VDC	A	15.0	26.0
Max. Strom @ 48VDC	A	12.7	26.0
Max. Gesch. @ 72VDC	m/s (in/s)	1.7 (67)	3.0 (119)
Max. Gesch. @ 48VDC	m/s (in/s)	1.1 (45)	2.0 (79)
Phasenwider. 25/80 °C	Ohm	3.1/3.7	1.0/1.2
Phaseninduktivität	mH	3.1	1.0
Therm. Widerstand	°K/W	1.1	1.1
Therm. Zeitkonstante	sec	3000	3000
Statordurchmesser	mm (in)	48 (1.89)	48 (1.89)
Statorlänge	mm (in)	290 (11.40)	290 (11.40)
Statormasse	g (lb)	1930 (4.25)	1930 (4.25)
Läuferdurchmesser	mm (in)	28 (1.10)	28 (1.10)
Läuferlänge	mm (in)	800 (31.50)	800 (31.50)
Läufermasse	g (lb)	3560 (7.85)	3560 (7.85)
Wiederholgenauigkeit	mm (in)	±0.05 (±0.0020)	±0.05 (±0.0020)
Linearität	%	±0.10	±0.10
Wiederholgenauigk. ES	mm (in)	±0.01 (±0.0004)	±0.01 (±0.0004)
Linearität ES	mm (in)	±0.01 (±0.0004)	±0.01 (±0.0004)

## Hub-Zeit Diagramm

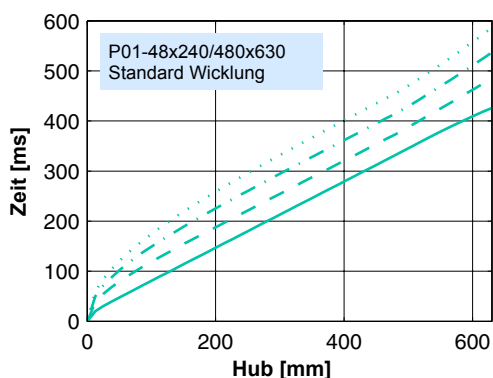

30.0 kg  
 20.0 kg  
 10.0 kg  
 0.0 kg

Bewegter Läufer

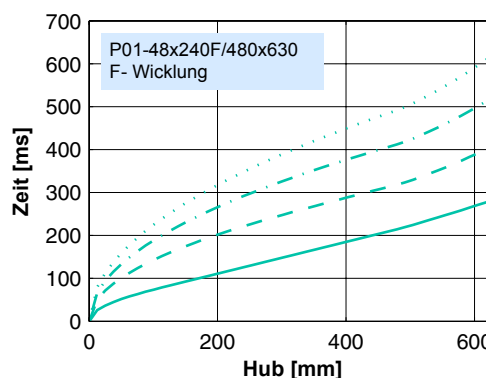

30.0 kg  
 20.0 kg  
 10.0 kg  
 0.0 kg

Bewegter Läufer

## Stecker Typ

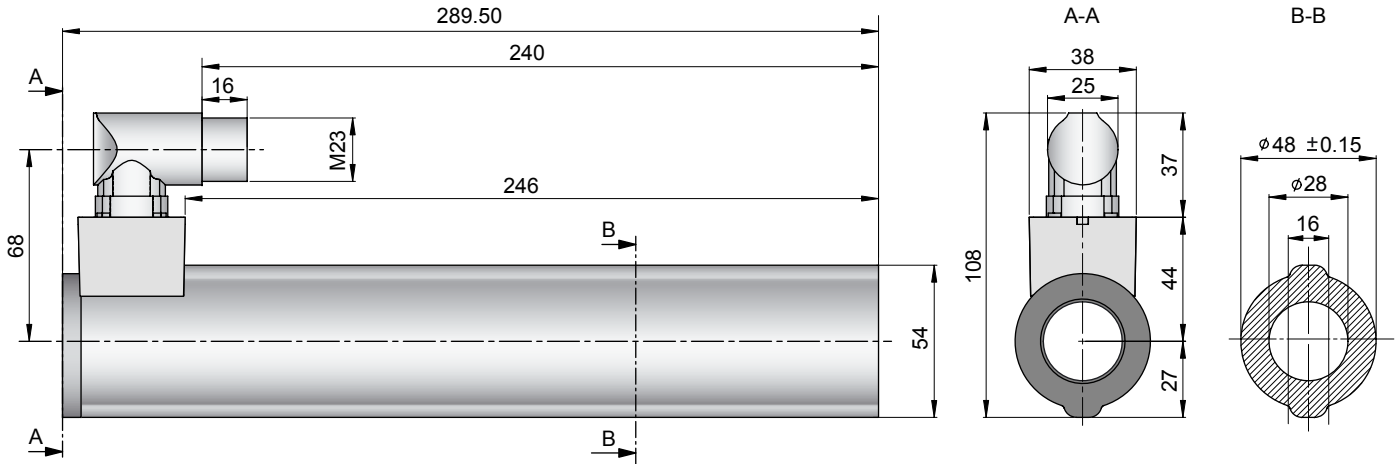

Linearmotor		Stator		Läufer	
Typ	Art. Nr.	Typ	Art. Nr.	Typ	Art. Nr.
P01-48x240/480x630-C	-->	PS01-48x240-C	0150-1219	&	PL01-28x800/720
P01-48x240F/480x630-C	-->	PS01-48x240F-C	0150-1220	&	PL01-28x800/720

P01-48x240/480x630

## Läufer

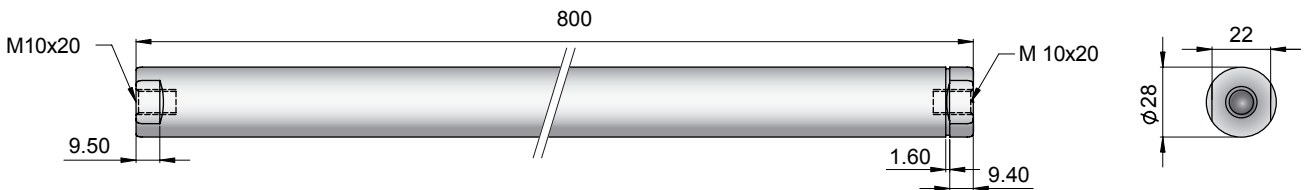

Standard Läufer	Standard Läufer	PL01-28x800/720	0150-1385
Spezialläufer	Heavy Duty Läufer mit WC/C-Beschichtung	PL02-28x800/720	0150-1416
	Lochläufer Innendurchmesser 8.5mm	PL01-28x800/720-L	0150-1483

## Stecker

### Motor Steckerbelegung

Motor Steckerbelegung		P01-48...-C
Ph 1+	rot	A
Ph 1-	pink	B
Ph 2+	blau	C
Ph 2-	grau	D
+5VDC	weiss	E
GND	innerer Schirm	F
Sinus	gelb	G
Cosinus	grün	H
Temp.	schwarz	L
Schirm	äusserer Schi.	Geh.

## Zubehör

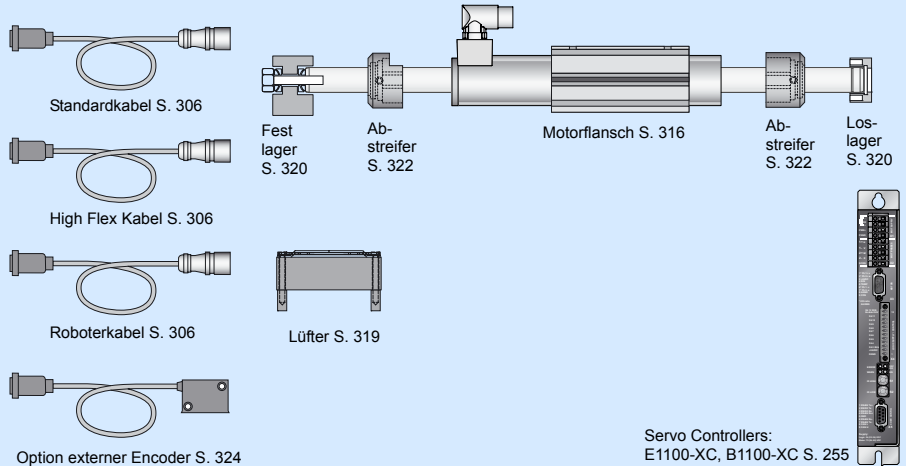

Servo Controllers:  
E1100-XC, B1100-XC S. 255

**Maximaler Hub: 750mm**  
**Spitzenkraft: 585N**

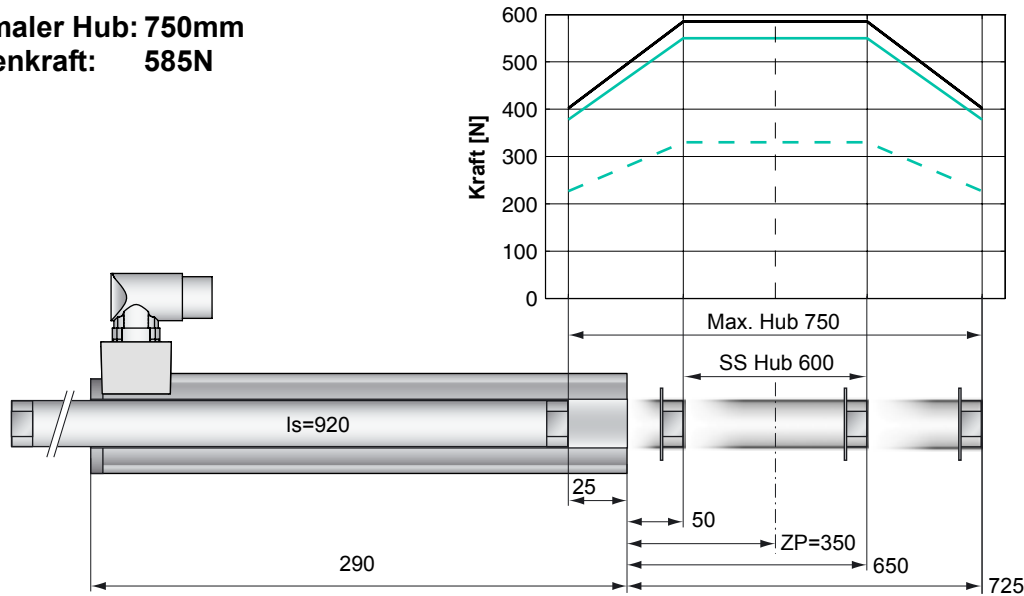

**Standard Wicklung:**  
 — E1100-XC, 72VDC  
 — E1100-HC, 72VDC

**F - Wicklung**  
 — E1100-XC, 72VDC  
 - - - E1100-HC, 72VDC

Abmessungen mm

## Motor Spezifikation

P01-		Standard Wicklung	F- Wicklung
		48x240/600x750-C	48x240F/600x750-C
Maximaler Hub	mm (in)	750 (29.53)	750 (29.53)
Kurzhubbereich SS	mm (in)	600 (23.62)	600 (23.62)
Spitzenkraft E1100-XC	N (lbf)	585 (131.5)	550 (123.6)
Spitzenkraft E1100-HC	N (lbf)	585 (131.5)	330 (74.2)
Kont. Kraft	N (lbf)	145 (32.5)	145 (32.6)
Kont. Kraft mit Lüfter	N (lbf)	258 (58.0)	255 (57.3)
Randkraft	%	69	69
Kraftkonstante	N/A (lbf/A)	39.0 (8.77)	22.0 (4.95)
Max. Strom @ 72VDC	A	15.0	26.0
Max. Strom @ 48VDC	A	12.7	26.0
Max. Gesch. @ 72VDC	m/s (in/s)	1.7 (67)	3.0 (119)
Max. Gesch. @ 48VDC	m/s (in/s)	1.1 (45)	2.0 (79)
Phasenwider. 25/80 °C	Ohm	3.1/3.7	1.0/1.2
Phaseninduktivität	mH	3.1	1.0
Therm. Widerstand	°K/W	1.1	1.1
Therm. Zeitkonstante	sec	3000	3000
Statordurchmesser	mm (in)	48 (1.89)	48 (1.89)
Statorlänge	mm (in)	290 (11.40)	290 (11.40)
Statormasse	g (lb)	1930 (4.25)	1930 (4.25)
Läuferdurchmesser	mm (in)	28 (1.10)	28 (1.10)
Läuferlänge	mm (in)	920 (36.22)	920 (36.22)
Läufermasse	g (lb)	4120 (9.08)	4120 (9.08)
Wiederholgenauigkeit	mm (in)	±0.05 (±0.0020)	±0.05 (±0.0020)
Linearität	%	±0.10	±0.10
Wiederholgenauigk. ES	mm (in)	±0.01 (±0.0004)	±0.01 (±0.0004)
Linearität ES	mm (in)	±0.01 (±0.0004)	±0.01 (±0.0004)

## Hub-Zeit Diagramm

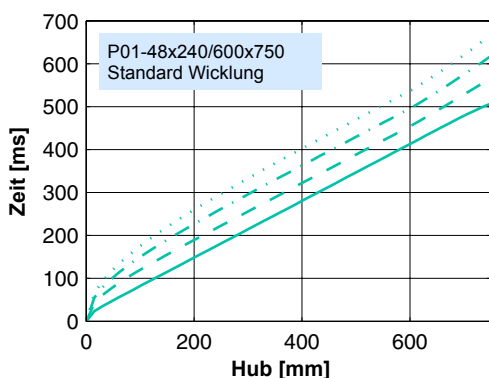

30.0 kg  
 20.0 kg  
 10.0 kg  
 0.0 kg

Bewegter Stator

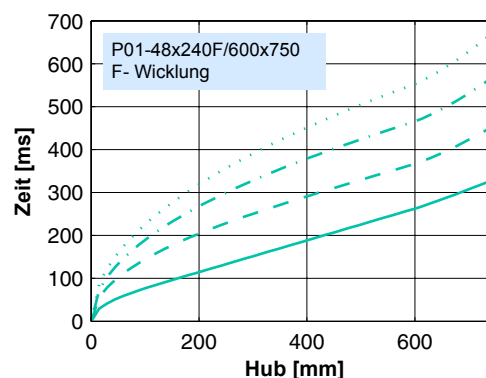

30.0 kg  
 20.0 kg  
 10.0 kg  
 0.0 kg

Bewegter Stator

## Stecker Typ

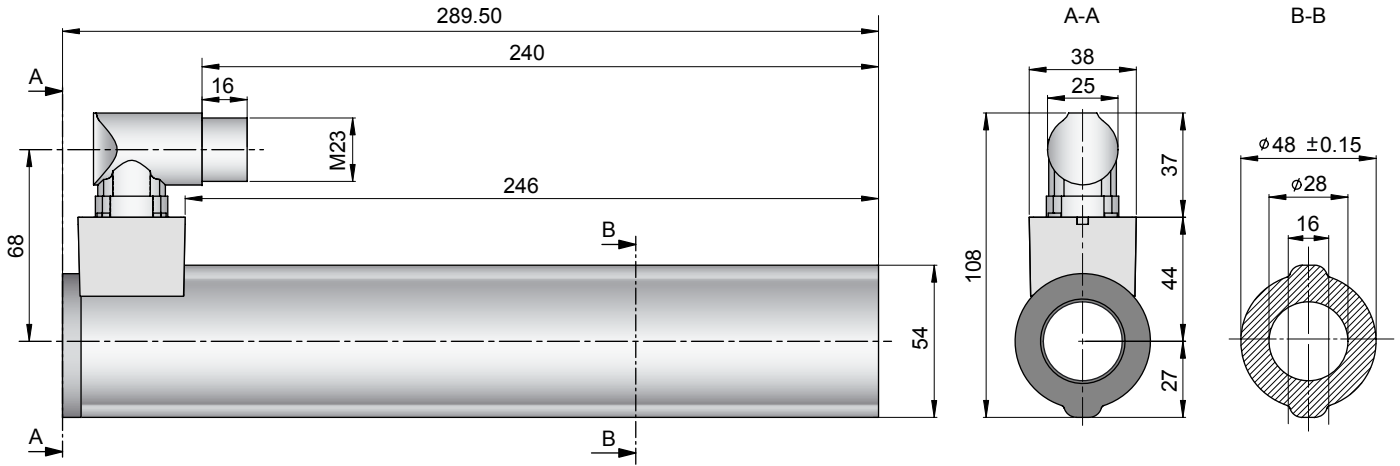

Linearmotor		Stator		Läufer		
Typ	Art. Nr.	Typ	Art. Nr.	Typ	Art. Nr.	
P01-48x240/600x750-C	-->	PS01-48x240-C	0150-1219	&	PL01-28x920/840	0150-1386
P01-48x240F/600x750-C	-->	PS01-48x240F-C	0150-1220	&	PL01-28x920/840	0150-1386

P01-48x240/600x750

## Läufer

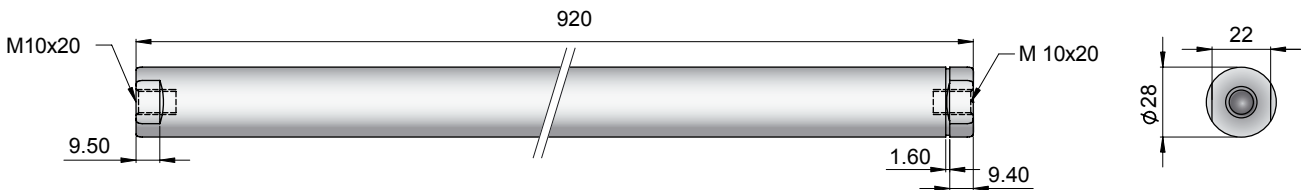

Standard Läufer	Standard Läufer	PL01-28x920/840	0150-1386
Spezialläufer	Heavy Duty Läufer mit WC/C-Beschichtung	PL02-28x920/840	0150-1417
	Lochläufer Innendurchmesser 8.5mm	PL01-28x920/840-L	auf Anfrage

## Stecker

### Motor Steckerbelegung

Motor Steckerbelegung		P01-48...-C
Ph 1+	rot	A
Ph 1-	pink	B
Ph 2+	blau	C
Ph 2-	grau	D
+5VDC	weiss	E
GND	innerer Schirm	F
Sinus	gelb	G
Cosinus	grün	H
Temp.	schwarz	L
Schirm	äusserer Schi.	Geh.

## Zubehör

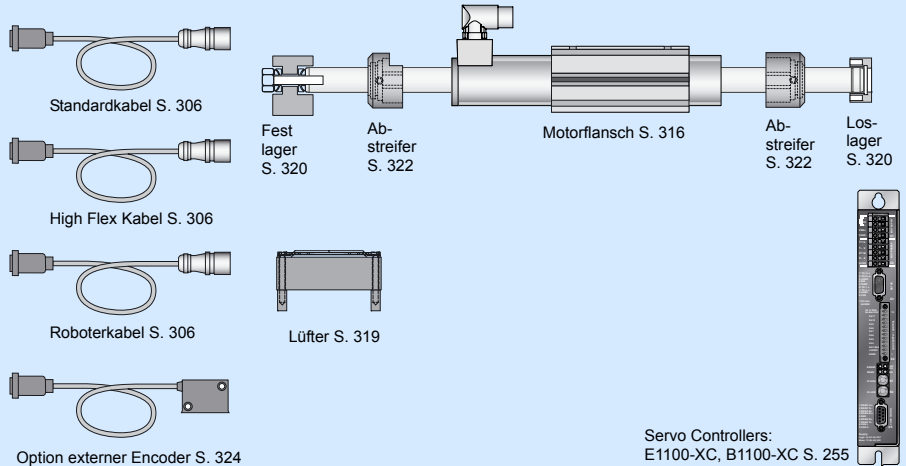

**Maximaler Hub: 840mm**  
**Spitzenkraft: 585N**

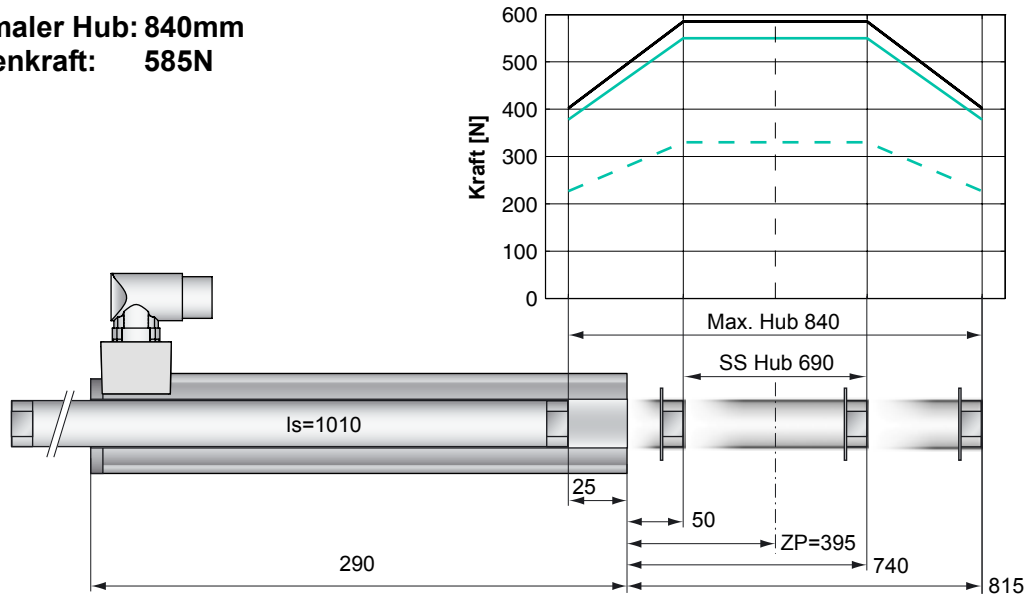

**Standard Wicklung:**  
 — E1100-XC, 72VDC  
 — E1100-HC, 72VDC

**F - Wicklung**  
 — E1100-XC, 72VDC  
 - - E1100-HC, 72VDC

Abmessungen mm

## Motor Spezifikation

P01-		Standard Wicklung	F- Wicklung
		48x240/690x840-C	48x240F/690x840-C
Maximaler Hub	mm (in)	840 (33.07)	840 (33.07)
Kurzhubbereich SS	mm (in)	690 (27.17)	690 (27.17)
Spitzenkraft E1100-XC	N (lbf)	585 (131.5)	550 (123.6)
Spitzenkraft E1100-HC	N (lbf)	585 (131.5)	330 (74.2)
Kont. Kraft	N (lbf)	145 (32.5)	145 (32.6)
Kont. Kraft mit Lüfter	N (lbf)	258 (58.0)	255 (57.3)
Randkraft	%	69	69
Kraftkonstante	N/A (lbf/A)	39.0 (8.77)	22.0 (4.95)
Max. Strom @ 72VDC	A	15.0	26.0
Max. Strom @ 48VDC	A	12.7	26.0
Max. Gesch. @ 72VDC	m/s (in/s)	1.7 (67)	3.0 (119)
Max. Gesch. @ 48VDC	m/s (in/s)	1.1 (45)	2.0 (79)
Phasenwider. 25/80 °C	Ohm	3.1/3.7	1.0/1.2
Phaseninduktivität	mH	3.1	1.0
Therm. Widerstand	°K/W	1.1	1.1
Therm. Zeitkonstante	sec	3000	3000
Statordurchmesser	mm (in)	48 (1.89)	48 (1.89)
Statorlänge	mm (in)	290 (11.40)	290 (11.40)
Statormasse	g (lb)	1930 (4.25)	1930 (4.25)
Läuferdurchmesser	mm (in)	28 (1.10)	28 (1.10)
Läuferlänge	mm (in)	1010 (39.76)	1010 (39.76)
Läufermasse	g (lb)	4540 (10.01)	4540 (10.01)
Wiederholgenauigkeit	mm (in)	±0.05 (±0.0020)	±0.05 (±0.0020)
Linearität	%	±0.10	±0.10
Wiederholgenauigk. ES	mm (in)	±0.01 (±0.0004)	±0.01 (±0.0004)
Linearität ES	mm (in)	±0.01 (±0.0004)	±0.01 (±0.0004)

## Hub-Zeit Diagramm

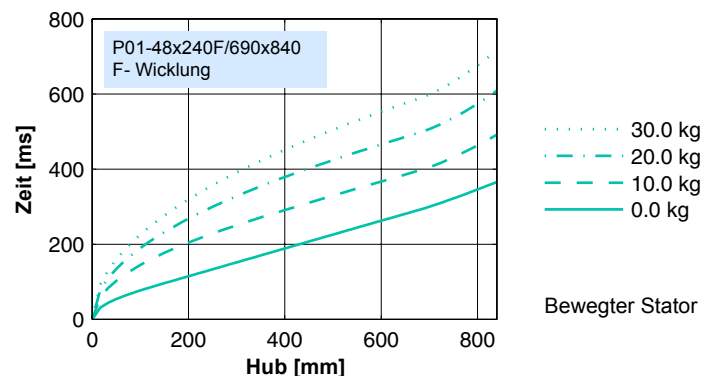
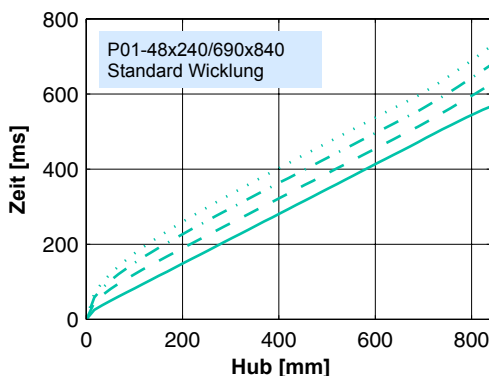

## Stecker Typ

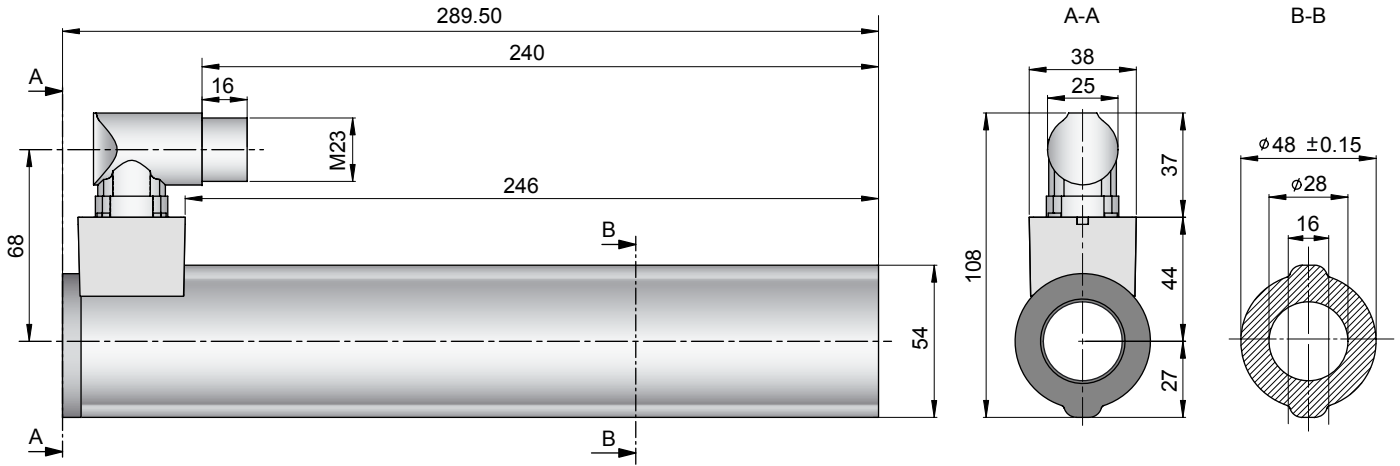

Linearmotor		Stator		Läufer		
Typ	Art. Nr.	Typ	Art. Nr.	&	Typ	Art. Nr.
P01-48x240/690x840-C	-->	PS01-48x240-C	0150-1219	&	PL01-28x1010/930	0150-1387
P01-48x240F/690x840-C	-->	PS01-48x240F-C	0150-1220	&	PL01-28x1010/930	0150-1387

P01-48x240/690x840

## Läufer

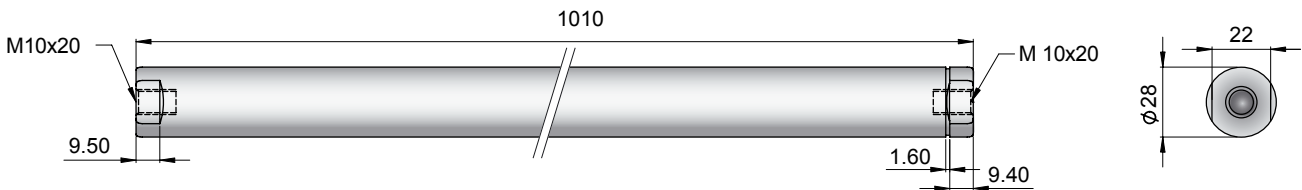

Standard Läufer	Standard Läufer	PL01-28x1010/930	0150-1387
Spezialläufer	Heavy Duty Läufer mit WC/C-Beschichtung	PL02-28x1010/930	auf Anfrage
	Lochläufer Innendurchmesser 8.5mm	PL01-28x1010/930-L	auf Anfrage

## Stecker

### Motor Steckerbelegung

Motor Steckerbelegung		P01-48...-C
Ph 1+	rot	A
Ph 1-	pink	B
Ph 2+	blau	C
Ph 2-	grau	D
+5VDC	weiss	E
GND	innerer Schirm	F
Sinus	gelb	G
Cosinus	grün	H
Temp.	schwarz	L
Schirm	äusserer Schi.	Geh.

## Zubehör

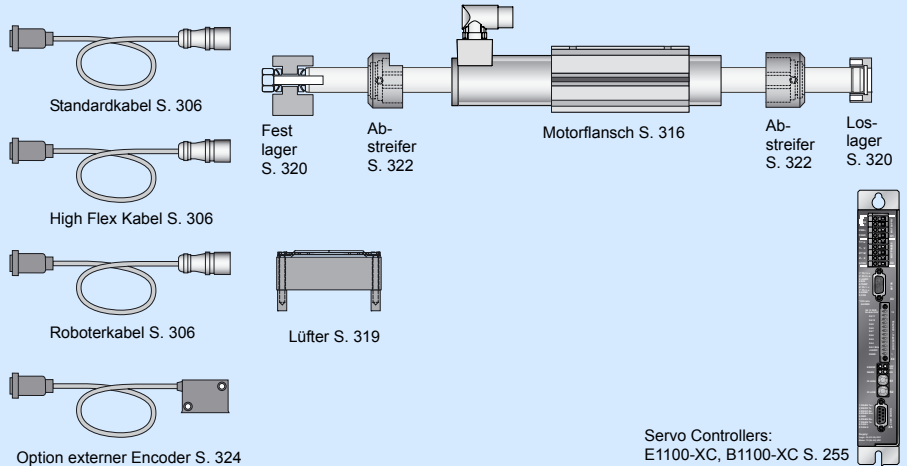

Servo Controllers:  
E1100-XC, B1100-XC S. 255

**Maximaler Hub: 1050mm**  
**Spitzenkraft: 585N**

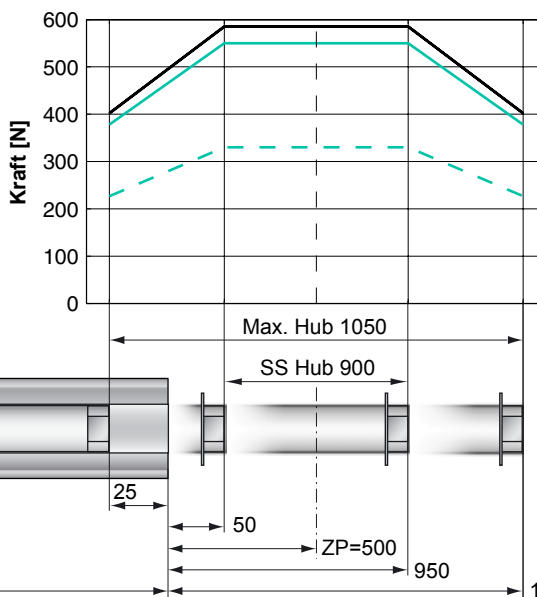

**Standard Wicklung:**  
 — E1100-XC, 72VDC  
 — E1100-HC, 72VDC

**F - Wicklung**  
 — E1100-XC, 72VDC  
 - - E1100-HC, 72VDC

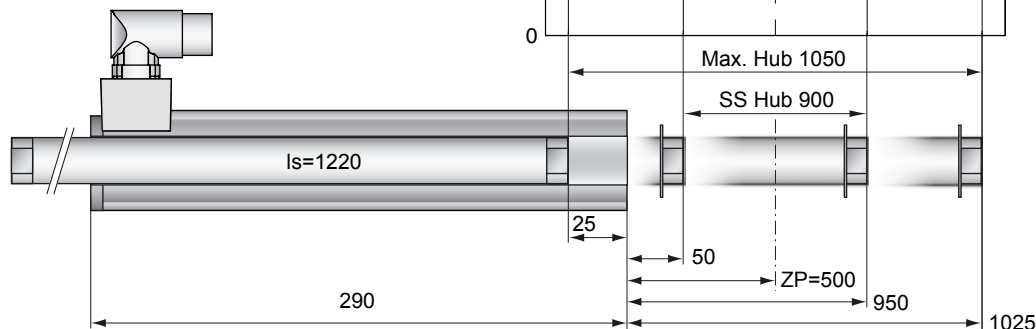

Abmessungen mm

## Motor Spezifikation

P01-		Standard Wicklung	F- Wicklung
		48x240/900x1050-C	48x240F/900x1050-C
Maximaler Hub	mm (in)	1050 (41.34)	1050 (41.34)
Kurzhubbereich SS	mm (in)	900 (35.43)	900 (35.43)
Spitzenkraft E1100-XC	N (lbf)	585 (131.5)	550 (123.6)
Spitzenkraft E1100-HC	N (lbf)	585 (131.5)	330 (74.2)
Kont. Kraft	N (lbf)	145 (32.5)	145 (32.6)
Kont. Kraft mit Lüfter	N (lbf)	258 (58.0)	255 (57.3)
Randkraft	%	69	69
Kraftkonstante	N/A (lbf/A)	39.0 (8.77)	22.0 (4.95)
Max. Strom @ 72VDC	A	15.0	26.0
Max. Strom @ 48VDC	A	12.7	26.0
Max. Gesch. @ 72VDC	m/s (in/s)	1.7 (67)	3.0 (119)
Max. Gesch. @ 48VDC	m/s (in/s)	1.1 (45)	2.0 (79)
Phasenwider. 25/80 °C	Ohm	3.1/3.7	1.0/1.2
Phaseninduktivität	mH	3.1	1.0
Therm. Widerstand	°K/W	1.1	1.1
Therm. Zeitkonstante	sec	3000	3000
Statordurchmesser	mm (in)	48 (1.89)	48 (1.89)
Statorlänge	mm (in)	290 (11.40)	290 (11.40)
Stormasse	g (lb)	1930 (4.25)	1930 (4.25)
Läuferdurchmesser	mm (in)	28 (1.10)	28 (1.10)
Läuferlänge	mm (in)	1220 (48.03)	1220 (48.03)
Läufermasse	g (lb)	5510 (12.15)	5510 (12.15)
Wiederholgenauigkeit	mm (in)	±0.05 (±0.0020)	±0.05 (±0.0020)
Linearität	%	±0.10	±0.10
Wiederholgenauigk. ES	mm (in)	±0.01 (±0.0004)	±0.01 (±0.0004)
Linearität ES	mm (in)	±0.01 (±0.0004)	±0.01 (±0.0004)

## Hub-Zeit Diagramm

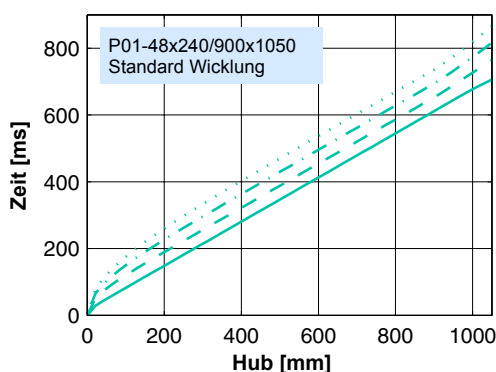

30.0 kg  
 20.0 kg  
 10.0 kg  
 0.0 kg

Bewegter Stator

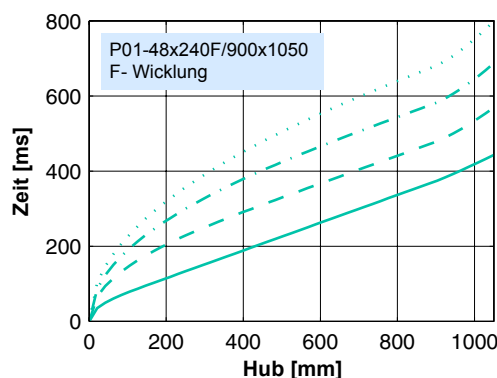

30.0 kg  
 20.0 kg  
 10.0 kg  
 0.0 kg

Bewegter Stator

## Stecker Typ

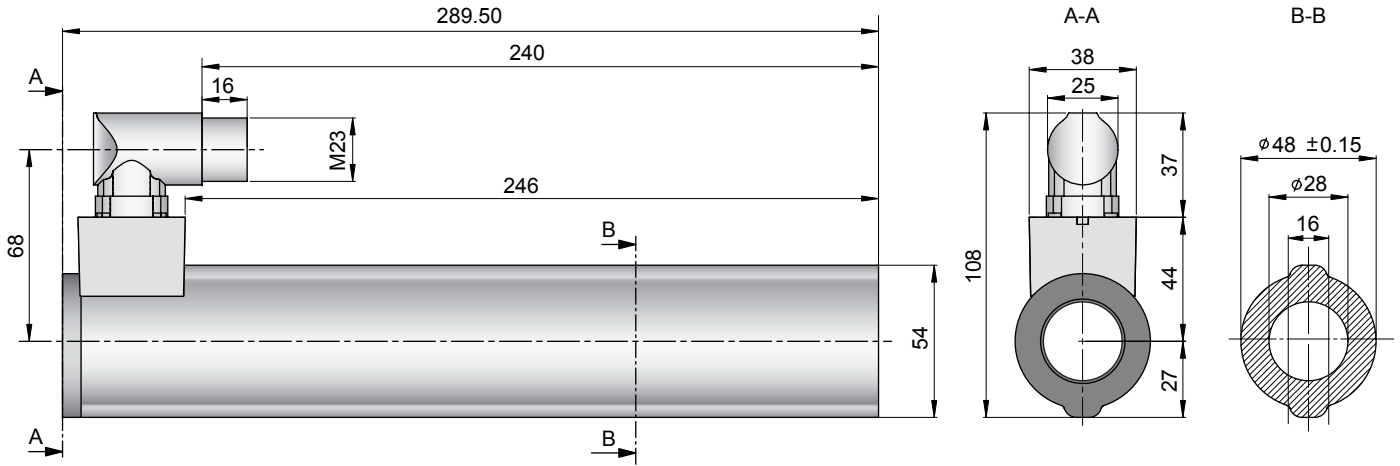

Linearmotor		Stator		Läufer	
Typ	Art. Nr.	Typ	Art. Nr.	Typ	Art. Nr.
P01-48x240/900x1050-C	-->	PS01-48x240-C	0150-1219	&	PL01-28x1220/1140
P01-48x240F/900x1050-C	-->	PS01-48x240F-C	0150-1220	&	PL01-28x1220/1140
					0150-1388

P01-48x240/900x1050

## Läufer

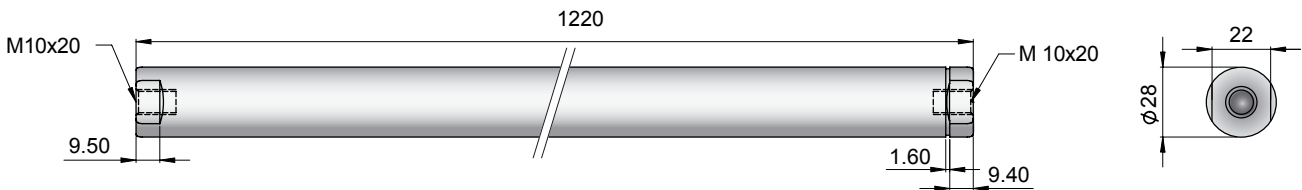

Standard Läufer	Standard Läufer	PL01-28x1220/1140	0150-1388
Spezialläufer	Heavy Duty Läufer mit WC/C-Beschichtung	PL02-28x1220/1140	auf Anfrage
	Lochläufer Innendurchmesser 8.5mm	PL01-28x1220/1140-L	auf Anfrage

## Stecker

### Motor Steckerbelegung

Motor Steckerbelegung		P01-48...-C
Ph 1+	rot	A
Ph 1-	pink	B
Ph 2+	blau	C
Ph 2-	grau	D
+5VDC	weiss	E
GND	innerer Schirm	F
Sinus	gelb	G
Cosinus	grün	H
Temp.	schwarz	L
Schirm	äusserer Schi.	Geh.

## Zubehör

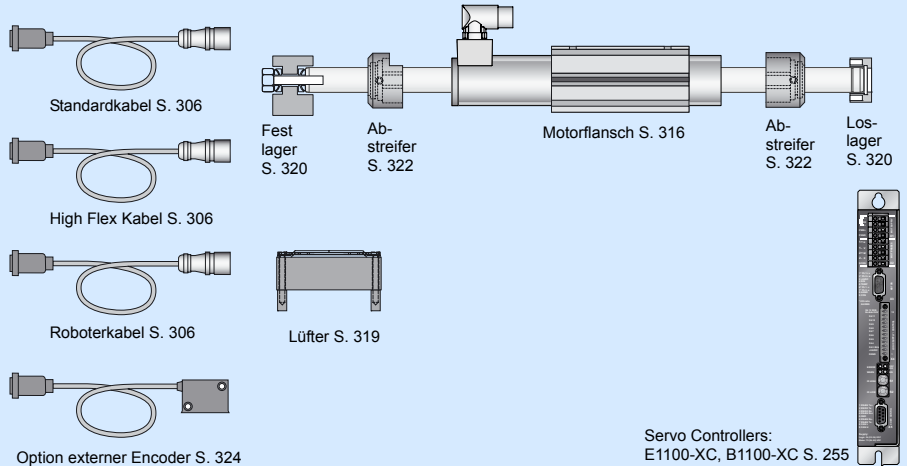

**Maximaler Hub: 1230mm**  
**Spitzenkraft: 585N**

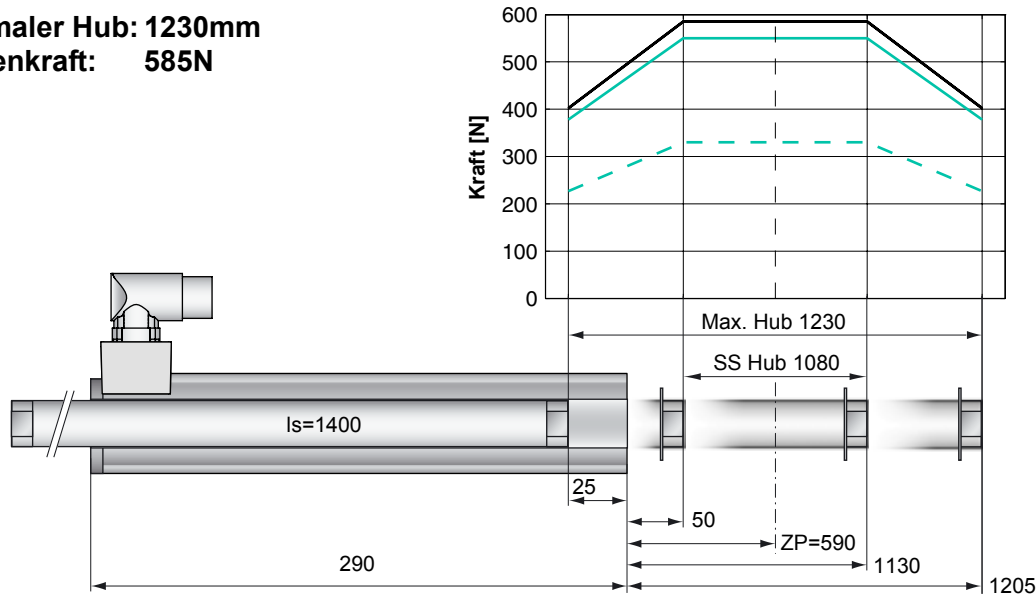

**Standard Wicklung:**  
 — E1100-XC, 72VDC  
 — E1100-HC, 72VDC

**F - Wicklung**  
 — E1100-XC, 72VDC  
 - - E1100-HC, 72VDC

Abmessungen mm

## Motor Spezifikation

P01-		Standard Wicklung	F- Wicklung
		48x240/1080x1230-C	48x240F/1080x1230-C
Maximaler Hub	mm (in)	1230 (48.43)	1230 (48.43)
Kurzhubbereich SS	mm (in)	1080 (42.52)	1080 (42.52)
Spitzenkraft E1100-XC	N (lbf)	585 (131.5)	550 (123.6)
Spitzenkraft E1100-HC	N (lbf)	585 (131.5)	330 (74.2)
Kont. Kraft	N (lbf)	145 (32.5)	145 (32.6)
Kont. Kraft mit Lüfter	N (lbf)	258 (58.0)	255 (57.3)
Randkraft	%	69	69
Kraftkonstante	N/A (lbf/A)	39.0 (8.77)	22.0 (4.95)
Max. Strom @ 72VDC	A	15.0	26.0
Max. Strom @ 48VDC	A	12.7	26.0
Max. Gesch. @ 72VDC	m/s (in/s)	1.7 (67)	3.0 (119)
Max. Gesch. @ 48VDC	m/s (in/s)	1.1 (45)	2.0 (79)
Phasenwider. 25/80 °C	Ohm	3.1/3.7	1.0/1.2
Phaseninduktivität	mH	3.1	1.0
Therm. Widerstand	°K/W	1.1	1.1
Therm. Zeitkonstante	sec	3000	3000
Statordurchmesser	mm (in)	48 (1.89)	48 (1.89)
Statorlänge	mm (in)	290 (11.40)	290 (11.40)
Statormasse	g (lb)	1930 (4.25)	1930 (4.25)
Läuferdurchmesser	mm (in)	28 (1.10)	28 (1.10)
Läuferlänge	mm (in)	1400 (55.12)	1400 (55.12)
Läufermasse	g (lb)	6350 (14.00)	6350 (14.00)
Wiederholgenauigkeit	mm (in)	±0.05 (±0.0020)	±0.05 (±0.0020)
Linearität	%	±0.10	±0.10
Wiederholgenauigk. ES	mm (in)	±0.01 (±0.0004)	±0.01 (±0.0004)
Linearität ES	mm (in)	±0.01 (±0.0004)	±0.01 (±0.0004)

## Hub-Zeit Diagramm

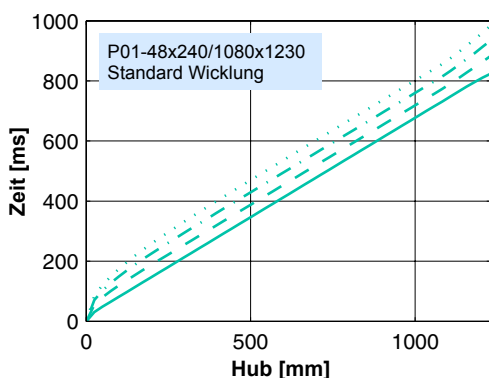

30.0 kg  
 20.0 kg  
 10.0 kg  
 0.0 kg

Bewegter Stator

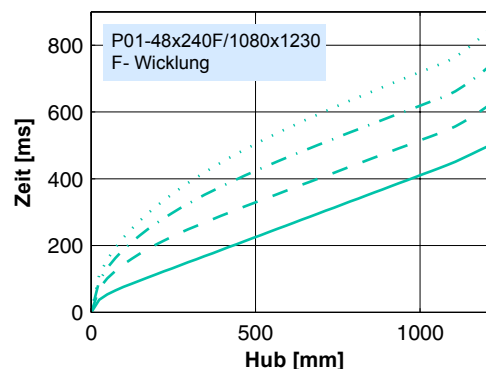

30.0 kg  
 20.0 kg  
 10.0 kg  
 0.0 kg

Bewegter Stator

## Stecker Typ

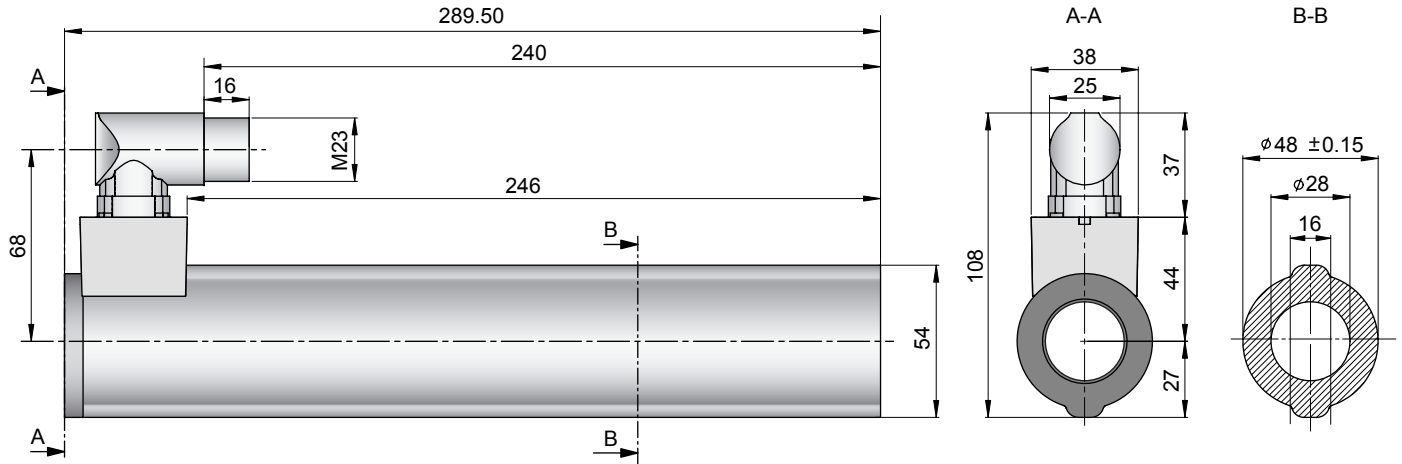

Linearmotor		Stator		Läufer		
Typ	Art. Nr.	Typ	Art. Nr.	Typ	Art. Nr.	
P01-48x240/1080x1230-C	-->	PS01-48x240-C	0150-1219	&	PL01-28x1400/1320	0150-1389
P01-48x240F/1080x1230-C	-->	PS01-48x240F-C	0150-1220	&	PL01-28x1400/1320	0150-1389

P01-48x240/1080x1230

## Läufer

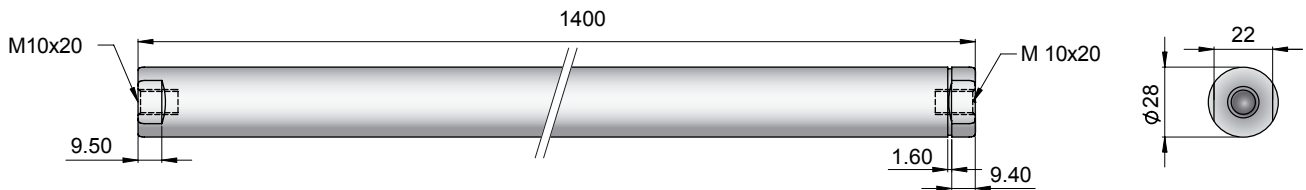

Standard Läufer	Standard Läufer	PL01-28x1400/1320	0150-1389
Spezialläufer	Heavy Duty Läufer mit WC/C-Beschichtung	PL02-28x1400/1320	auf Anfrage
	Lochläufer Innendurchmesser 8.5mm	PL01-28x1400/1320-L	auf Anfrage

## Stecker

### Motor Steckerbelegung

Motor Steckerbelegung		P01-48...-C
Ph 1+	rot	A
Ph 1-	pink	B
Ph 2+	blau	C
Ph 2-	grau	D
+5VDC	weiss	E
GND	innerer Schirm	F
Sinus	gelb	G
Cosinus	grün	H
Temp.	schwarz	L
Schirm	äusserer Schi.	Geh.

## Zubehör

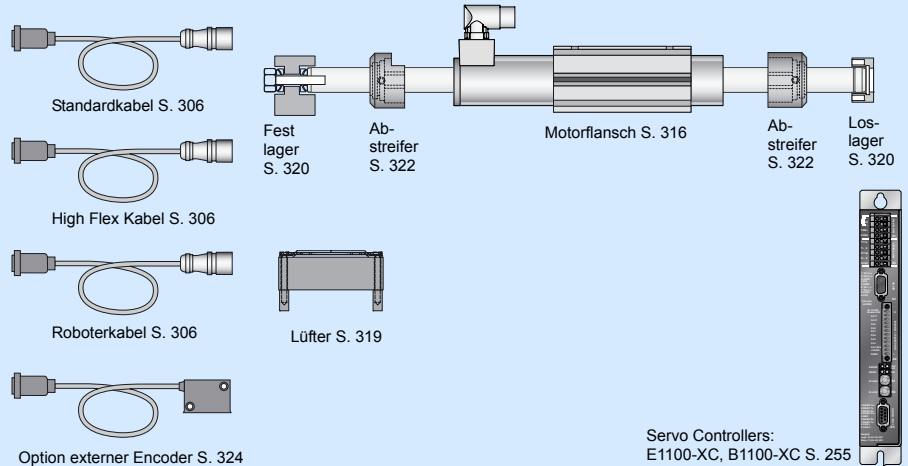

**Maximaler Hub: 1440mm**  
**Spitzenkraft: 585N**

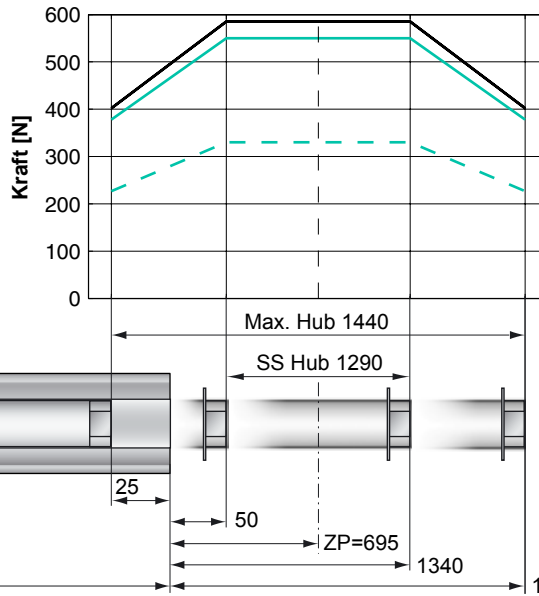

**Standard Wicklung:**  
 — E1100-XC, 72VDC  
 - - E1100-HC, 72VDC

**F - Wicklung**  
 — E1100-XC, 72VDC  
 - - E1100-HC, 72VDC

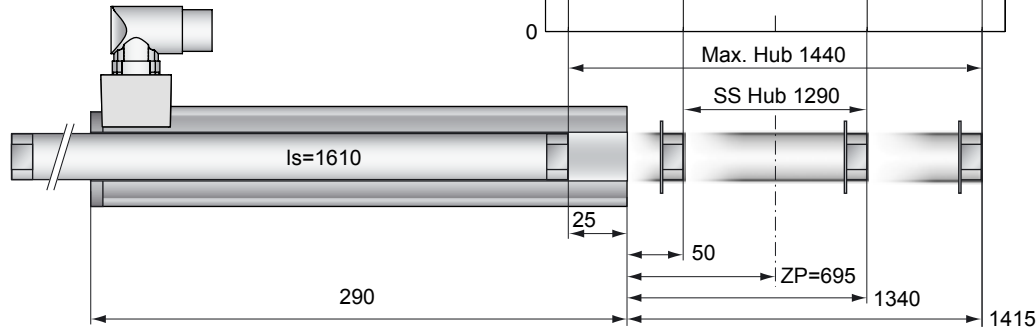

Abmessungen mm

## Motor Spezifikation

P01-		Standard Wicklung	F- Wicklung
		48x240/1290x1440-C	48x240F/1290x1440-C
Maximaler Hub	mm (in)	1440 (56.69)	1440 (56.69)
Kurzhubbereich SS	mm (in)	1290 (50.79)	1290 (50.79)
Spitzenkraft E1100-XC	N (lbf)	585 (131.5)	550 (123.6)
Spitzenkraft E1100-HC	N (lbf)	585 (131.5)	330 (74.2)
Kont. Kraft	N (lbf)	145 (32.5)	145 (32.6)
Kont. Kraft mit Lüfter	N (lbf)	258 (58.0)	255 (57.3)
Randkraft	%	69	69
Kraftkonstante	N/A (lbf/A)	39.0 (8.77)	22.0 (4.95)
Max. Strom @ 72VDC	A	15.0	26.0
Max. Strom @ 48VDC	A	12.7	26.0
Max. Gesch. @ 72VDC	m/s (in/s)	1.7 (67)	3.0 (119)
Max. Gesch. @ 48VDC	m/s (in/s)	1.1 (45)	2.0 (79)
Phasenwider. 25/80 °C	Ohm	3.1/3.7	1.0/1.2
Phaseninduktivität	mH	3.1	1.0
Therm. Widerstand	°K/W	1.1	1.1
Therm. Zeitkonstante	sec	3000	3000
Statordurchmesser	mm (in)	48 (1.89)	48 (1.89)
Statorlänge	mm (in)	290 (11.40)	290 (11.40)
Statormasse	g (lb)	1930 (4.25)	1930 (4.25)
Läuferdurchmesser	mm (in)	28 (1.10)	28 (1.10)
Läuferlänge	mm (in)	1610 (63.39)	1610 (63.39)
Läufermasse	g (lb)	7330 (16.16)	7330 (16.16)
Wiederholgenauigkeit	mm (in)	±0.05 (±0.0020)	±0.05 (±0.0020)
Linearität	%	±0.10	±0.10
Wiederholgenauigk. ES	mm (in)	±0.01 (±0.0004)	±0.01 (±0.0004)
Linearität ES	mm (in)	±0.01 (±0.0004)	±0.01 (±0.0004)

## Hub-Zeit Diagramm

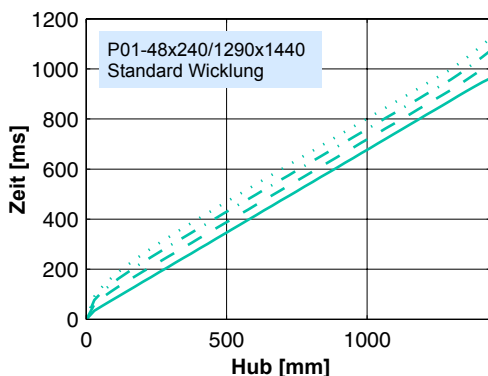

30.0 kg  
 20.0 kg  
 10.0 kg  
 0.0 kg

Bewegter Stator

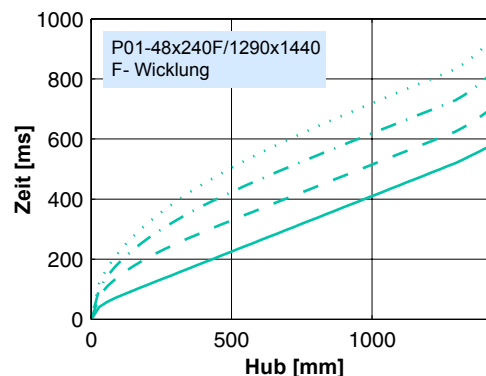

30.0 kg  
 20.0 kg  
 10.0 kg  
 0.0 kg

Bewegter Stator

## Stecker Typ

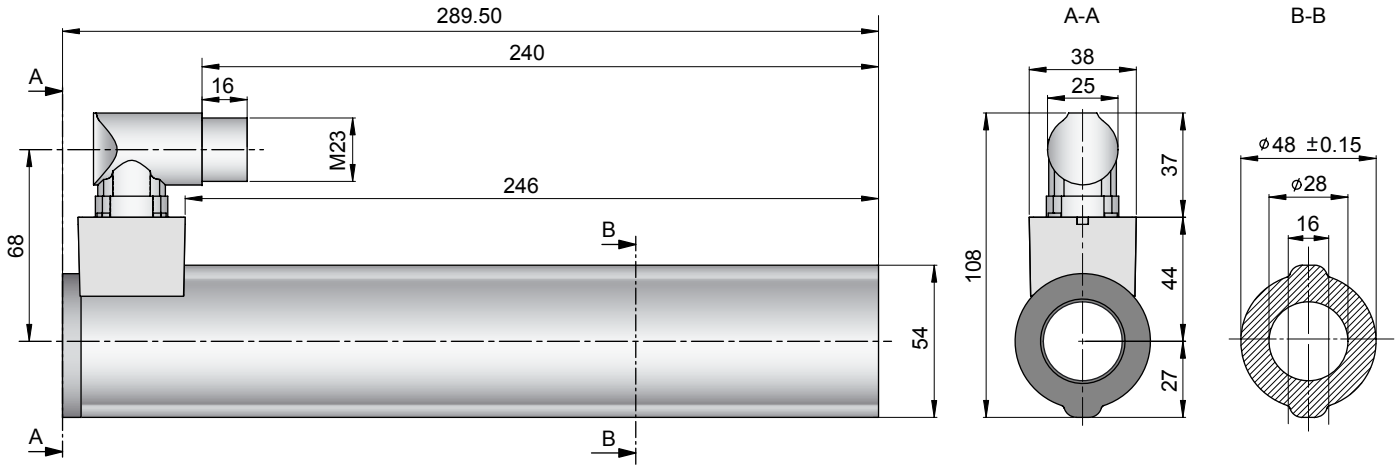

Linearmotor		Stator		Läufer		
Typ	Art. Nr.	Typ	Art. Nr.	Typ	Art. Nr.	
P01-48x240/1290x1440-C	-->	PS01-48x240-C	0150-1219	&	PL01-28x1610/1530	0150-1390
P01-48x240F/1290x1440-C	-->	PS01-48x240F-C	0150-1220	&	PL01-28x1610/1530	0150-1390

## Läufer

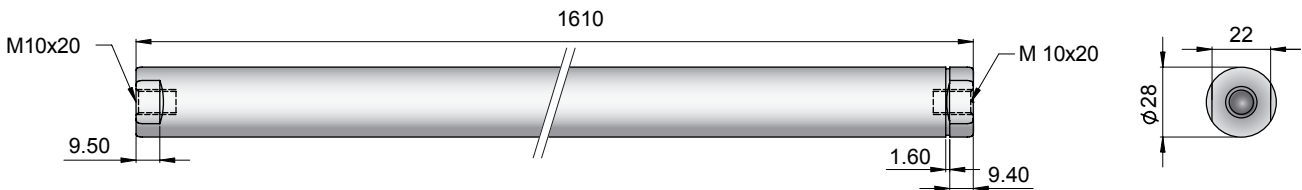

Standard Läufer	Standard Läufer	PL01-28x1610/1530	0150-1390
Spezialläufer	Heavy Duty Läufer mit WC/C-Beschichtung	PL02-28x1610/1530	auf Anfrage
	Lochläufer Innendurchmesser 8.5mm	PL01-28x1610/1530-L	auf Anfrage

## Stecker

### Motor Steckerbelegung

Motor Steckerbelegung		P01-48...-C
Ph 1+	rot	A
Ph 1-	pink	B
Ph 2+	blau	C
Ph 2-	grau	D
+5VDC	weiss	E
GND	innerer Schirm	F
Sinus	gelb	G
Cosinus	grün	H
Temp.	schwarz	L
Schirm	äusserer Schi.	Geh.

## Zubehör

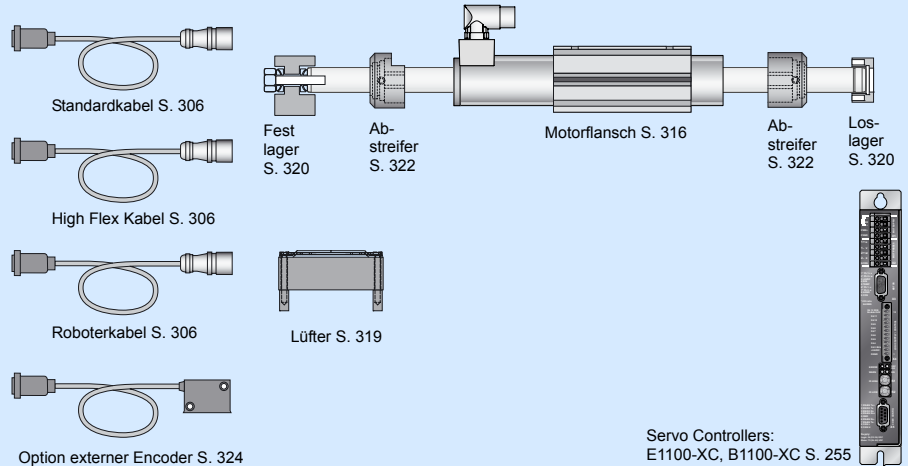

Servo Controllers:  
E1100-XC, B1100-XC S. 255

**Maximaler Hub: 1650mm**  
**Spitzenkraft: 585N**

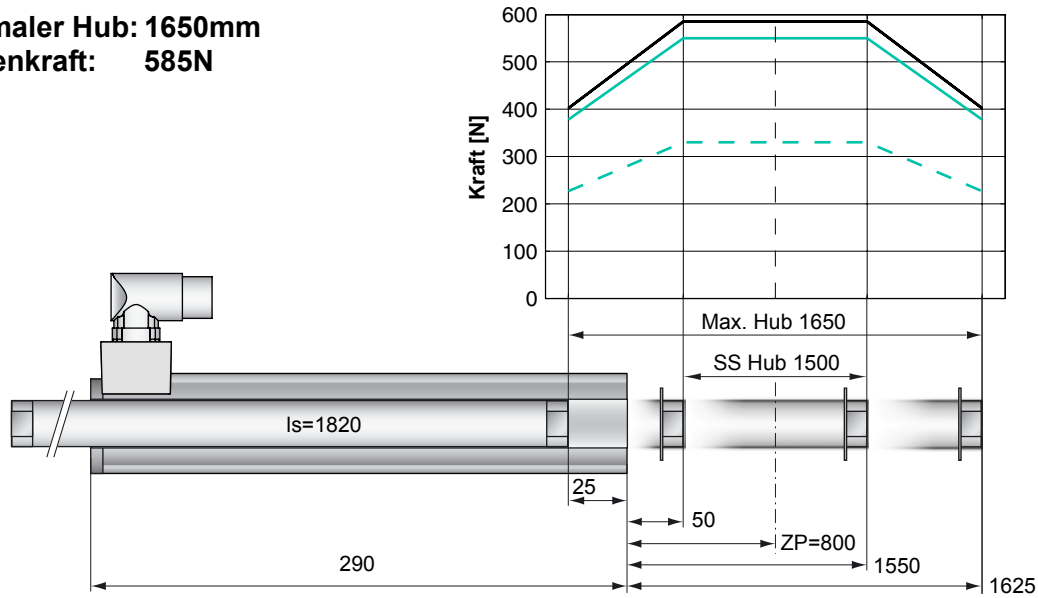

**Standard Wicklung:**  
 — E1100-XC, 72VDC  
 — E1100-HC, 72VDC

**F - Wicklung**  
 — E1100-XC, 72VDC  
 - - E1100-HC, 72VDC

Abmessungen mm

## Motor Spezifikation

P01-		Standard Wicklung	F- Wicklung
		48x240/1500x1650-C	48x240F/1500x1650-C
Maximaler Hub	mm (in)	1650 (64.96)	1650 (64.96)
Kurzhubbereich SS	mm (in)	1500 (59.06)	1500 (59.06)
Spitzenkraft E1100-XC	N (lbf)	585 (131.5)	550 (123.6)
Spitzenkraft E1100-HC	N (lbf)	585 (131.5)	330 (74.2)
Kont. Kraft	N (lbf)	145 (32.5)	145 (32.6)
Kont. Kraft mit Lüfter	N (lbf)	258 (58.0)	255 (57.3)
Randkraft	%	69	69
Kraftkonstante	N/A (lbf/A)	39.0 (8.77)	22.0 (4.95)
Max. Strom @ 72VDC	A	15.0	26.0
Max. Strom @ 48VDC	A	12.7	26.0
Max. Gesch. @ 72VDC	m/s (in/s)	1.7 (67)	3.0 (119)
Max. Gesch. @ 48VDC	m/s (in/s)	1.1 (45)	2.0 (79)
Phasenwider. 25/80 °C	Ohm	3.1/3.7	1.0/1.2
Phaseninduktivität	mH	3.1	1.0
Therm. Widerstand	°K/W	1.1	1.1
Therm. Zeitkonstante	sec	3000	3000
Statordurchmesser	mm (in)	48 (1.89)	48 (1.89)
Statorlänge	mm (in)	290 (11.40)	290 (11.40)
Statormasse	g (lb)	1930 (4.25)	1930 (4.25)
Läuferdurchmesser	mm (in)	28 (1.10)	28 (1.10)
Läuferlänge	mm (in)	1820 (71.65)	1820 (71.65)
Läufermasse	g (lb)	8300 (18.30)	8300 (18.30)
Wiederholgenauigkeit	mm (in)	±0.05 (±0.0020)	±0.05 (±0.0020)
Linearität	%	±0.10	±0.10
Wiederholgenauigk. ES	mm (in)	±0.01 (±0.0004)	±0.01 (±0.0004)
Linearität ES	mm (in)	±0.01 (±0.0004)	±0.01 (±0.0004)

## Hub-Zeit Diagramm

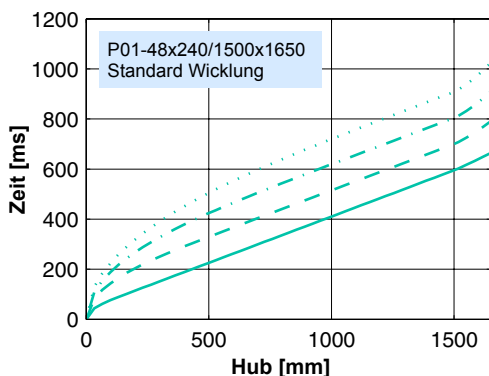

30.0 kg  
 20.0 kg  
 10.0 kg  
 0.0 kg

Bewegter Stator

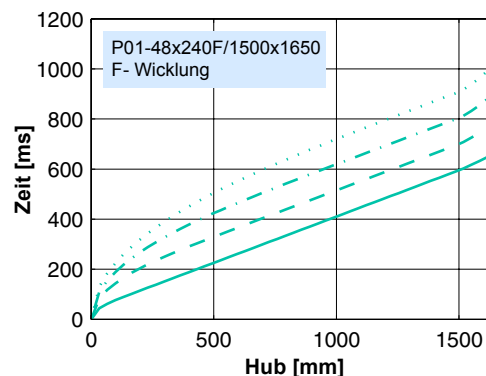

30.0 kg  
 20.0 kg  
 10.0 kg  
 0.0 kg

Bewegter Stator

## Stecker Typ

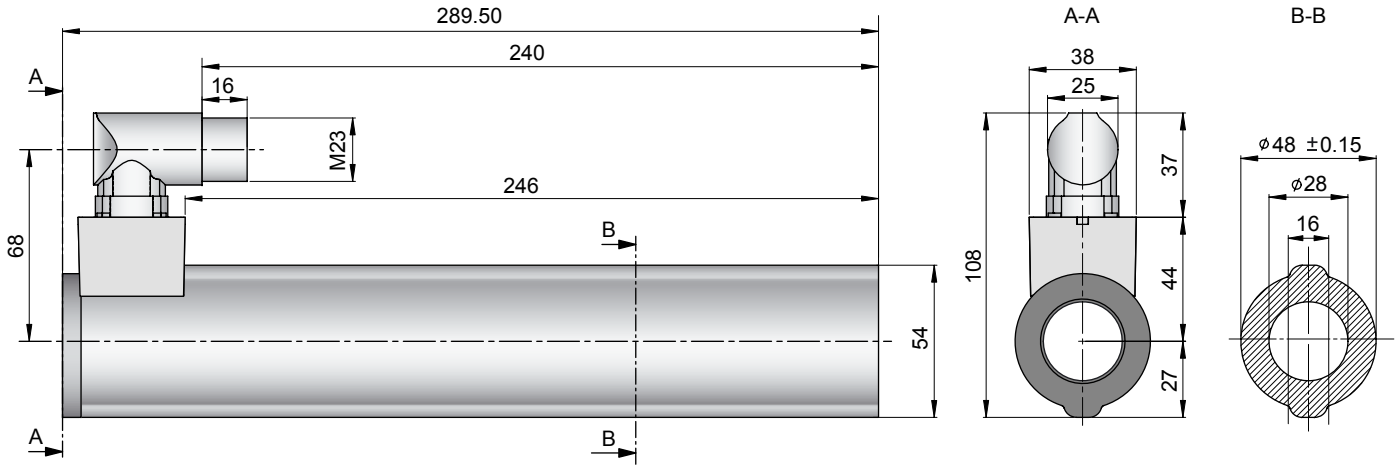

Linearmotor		Stator		Läufer	
Typ	Art. Nr.	Typ	Art. Nr.	Typ	Art. Nr.
P01-48x240/1500x1650-C	-->	PS01-48x240-C	0150-1219	&	PL01-28x1820/1740
P01-48x240F/1500x1650-C	-->	PS01-48x240F-C	0150-1220	&	PL01-28x1820/1740
					0150-1395

## Läufer

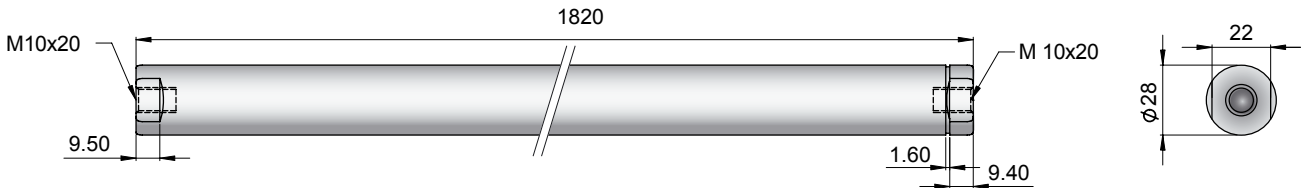

Standard Läufer	Standard Läufer	PL01-28x1820/1740	0150-1395
Spezialläufer	Heavy Duty Läufer mit WC/C-Beschichtung	PL02-28x1820/1740	auf Anfrage
	Lochläufer Innendurchmesser 8.5mm	PL01-28x1820/1740-L	auf Anfrage

## Stecker

### Motor Steckerbelegung

Motor Steckerbelegung		P01-48...-C
Ph 1+	rot	A
Ph 1-	pink	B
Ph 2+	blau	C
Ph 2-	grau	D
+5VDC	weiss	E
GND	innerer Schirm	F
Sinus	gelb	G
Cosinus	grün	H
Temp.	schwarz	L
Schirm	äusserer Schi.	Geh.

## Zubehör

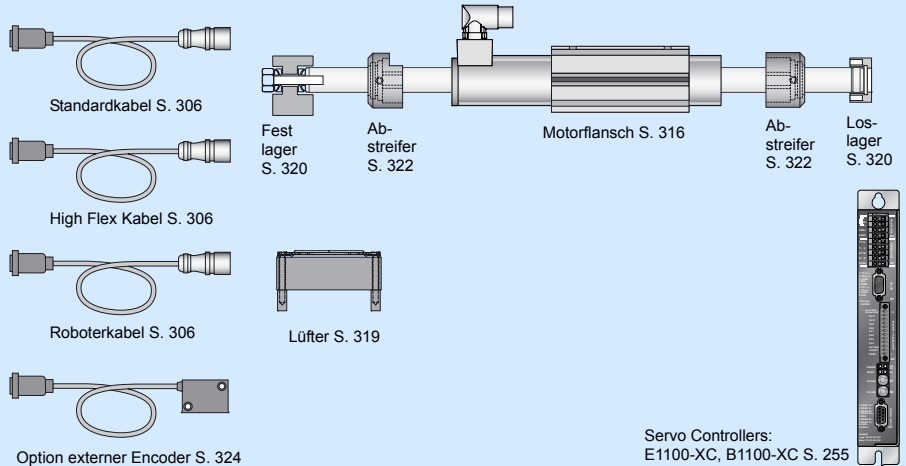

**Maximaler Hub: 1830mm**  
**Spitzenkraft: 585N**

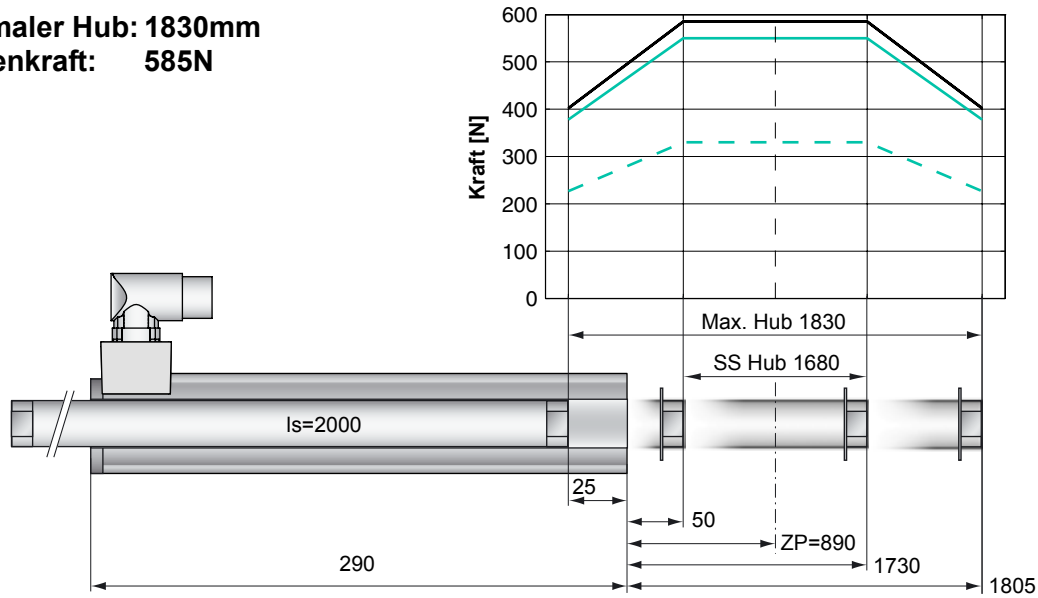

**Standard Wicklung:**  
 — E1100-XC, 72VDC  
 — E1100-HC, 72VDC

**F - Wicklung**  
 — E1100-XC, 72VDC  
 - - - E1100-HC, 72VDC

Abmessungen mm

## Motor Spezifikation

P01-		Standard Wicklung	F- Wicklung
		48x240/1680x1830-C	48x240F/1680x1830-C
Maximaler Hub	mm (in)	1830 (72.05)	1830 (72.05)
Kurzhubbereich SS	mm (in)	1680 (66.14)	1680 (66.14)
Spitzenkraft E1100-XC	N (lbf)	585 (131.5)	550 (123.6)
Spitzenkraft E1100-HC	N (lbf)	585 (131.5)	330 (74.2)
Kont. Kraft	N (lbf)	145 (32.5)	145 (32.6)
Kont. Kraft mit Lüfter	N (lbf)	258 (58.0)	255 (57.3)
Randkraft	%	69	69
Kraftkonstante	N/A (lbf/A)	39.0 (8.77)	22.0 (4.95)
Max. Strom @ 72VDC	A	15.0	26.0
Max. Strom @ 48VDC	A	12.7	26.0
Max. Gesch. @ 72VDC	m/s (in/s)	1.7 (67)	3.0 (119)
Max. Gesch. @ 48VDC	m/s (in/s)	1.1 (45)	2.0 (79)
Phasenwider. 25/80 °C	Ohm	3.1/3.7	1.0/1.2
Phaseninduktivität	mH	3.1	1.0
Therm. Widerstand	°K/W	1.1	1.1
Therm. Zeitkonstante	sec	3000	3000
Statordurchmesser	mm (in)	48 (1.89)	48 (1.89)
Statorlänge	mm (in)	290 (11.40)	290 (11.40)
Statormasse	g (lb)	1930 (4.25)	1930 (4.25)
Läuferdurchmesser	mm (in)	28 (1.10)	28 (1.10)
Läuferlänge	mm (in)	2000 (78.74)	2000 (78.74)
Läufermasse	g (lb)	9140 (20.15)	9140 (20.15)
Wiederholgenauigkeit	mm (in)	±0.05 (±0.0020)	±0.05 (±0.0020)
Linearität	%	±0.10	±0.10
Wiederholgenauigk. ES	mm (in)	±0.01 (±0.0004)	±0.01 (±0.0004)
Linearität ES	mm (in)	±0.01 (±0.0004)	±0.01 (±0.0004)

## Hub-Zeit Diagramm

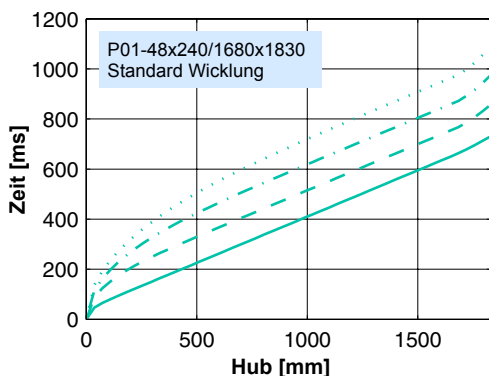

30.0 kg  
 20.0 kg  
 10.0 kg  
 0.0 kg

Bewegter Stator

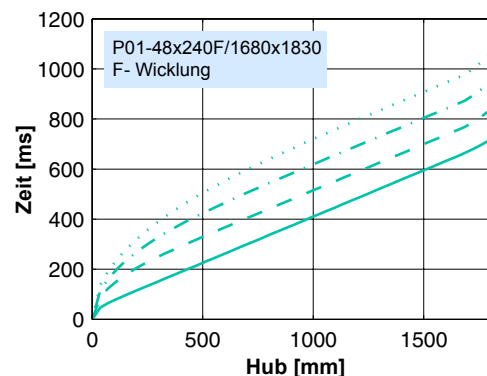

30.0 kg  
 20.0 kg  
 10.0 kg  
 0.0 kg

Bewegter Stator

## Stecker Typ

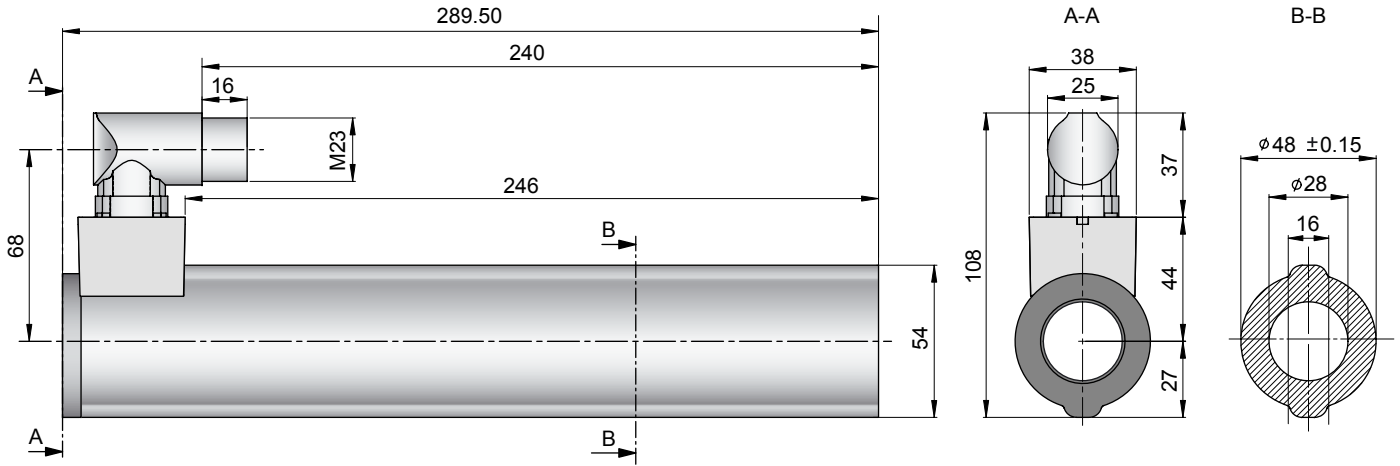

Linearmotor		Stator		Läufer		
Typ	Art. Nr.	Typ	Art. Nr.	Typ	Art. Nr.	
P01-48x240/1680x1830-C	-->	PS01-48x240-C	0150-1219	&	PL01-28x2000/1920	0150-1396
P01-48x240F/1680x1830-C	-->	PS01-48x240F-C	0150-1220	&	PL01-28x2000/1920	0150-1396

P01-48x240/1680x1830

## Läufer

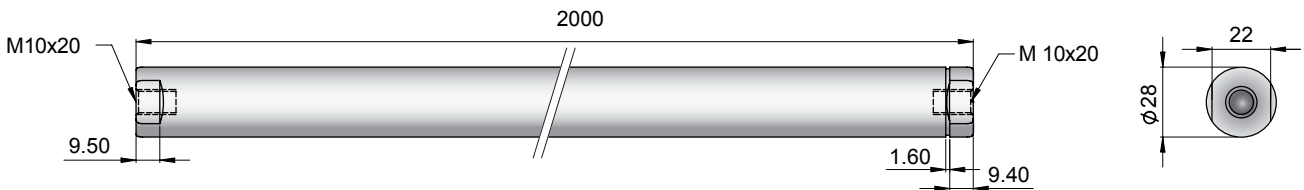

Standard Läufer	Standard Läufer	PL01-28x2000/1920	0150-1396
Spezialläufer	Heavy Duty Läufer mit WC/C-Beschichtung	PL02-28x2000/1920	auf Anfrage
	Lochläufer Innendurchmesser 8.5mm	PL01-28x2000/1920-L	auf Anfrage

## Stecker

### Motor Steckerbelegung

Motor Steckerbelegung		P01-48...-C
Ph 1+	rot	A
Ph 1-	pink	B
Ph 2+	blau	C
Ph 2-	grau	D
+5VDC	weiss	E
GND	innerer Schirm	F
Sinus	gelb	G
Cosinus	grün	H
Temp.	schwarz	L
Schirm	äusserer Schi.	Geh.

## Zubehör

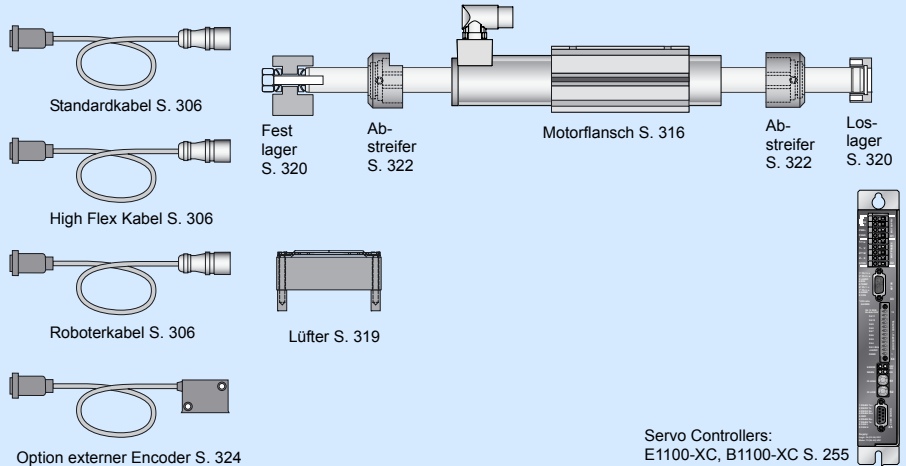

Servo Controllers:  
E1100-XC, B1100-XC S. 255