

Brake Resistors

Brake resistors are used to dissipate energy that is transferred back from the motor during the drive during regeneration – for example when stopping or slowing down high inertia loads. Invertek drives range of brake resistors are suitable for light duty braking (5%), without high repeat cycle times. For applications which require high braking power or frequent usage, alternative resistors should be used.

Important Safety Information

This option is specifically designed to be used with the Optidrive variable speed drive product range and is intended for professional incorporation into complete equipment or systems. If installed incorrectly it may present a safety hazard. The Optidrive uses high voltages and currents, carries a high level of stored electrical energy, and is used to control mechanical plant that may cause injury. Close attention is required to system design and electrical installation to avoid hazards in either normal operation or in the event of equipment malfunction. Optidrives and the Options should be installed only by qualified electrical persons and in accordance with local and national regulations and codes of practice.

Electric shock hazard! Disconnect and **ISOLATE** the Optidrive before attempting any work on it. High voltages are present at the terminals and within the drive for up to 10 minutes after disconnection of the electrical supply.

Where the electrical supply to the drive is through a plug and socket connector, do not disconnect until 10 minutes have elapsed after turning off the supply. It is the responsibility of the installer to ensure that the equipment or system into which the product is incorporated complies with the EMC legislation of the country of use. Within the European Union, equipment into which this product is incorporated must comply with 2004/108/EC, Electromagnetic Compatibility.

Within the European Union, all machinery in which this product is used must comply with the Directive 98/37/EC, Safety of Machinery. In particular, the equipment should comply with EN60204-1.

The manufacturer accepts no liability for any consequences resulting from inappropriate, negligent or incorrect installation.

The contents of this User Guide are believed to be correct at the time of printing. In the interests of a commitment to a policy of continuous improvement, the manufacturer reserves the right to change the specification of the product or its performance or the contents of the User Guide without notice.

Technical Data

Part Number	Optidrive Size	Resistance	Rated Voltage	Rated Power (W)		L (mm)	H (mm)	B (mm)	Weight (kg)
				Continuous	Peak				
OD-BR100-IN	2, 3	100	900 VDC	200	12000	188	40	9	
OD-BRES4-IN	4, 5	22	900 VDC	500	21000	330	80	10	

Mechanical Installation – Frame Size 2 & 3 Drives (IP20)

The OD-BR100-IN Resistor should be mounted to the drive heatsink. The rated power capacity shown above can only be achieved if the resistor is mounted in this way, to aid heat dissipation. The resistor should be slid into the drive via the rearmost slot on the bottom of the drive. The flat face of the resistor must face the front of the drive. It can then be held in place, using two supplied screws inserted into the threaded holes marked "A" below.

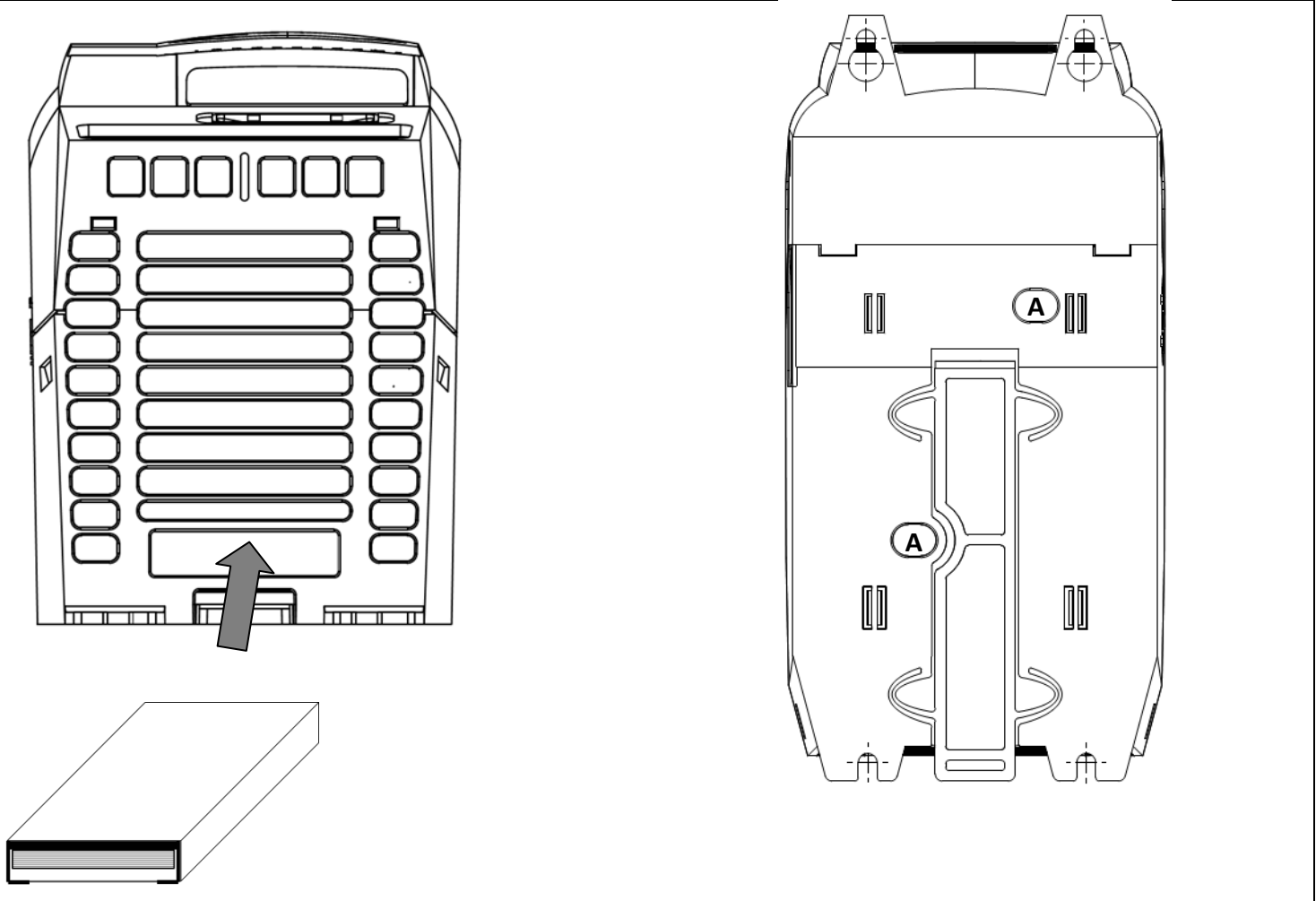

Mechanical Installation – Frame Size 4

Figure 1

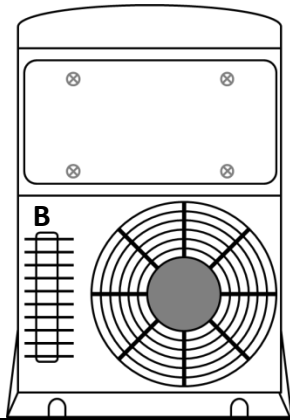
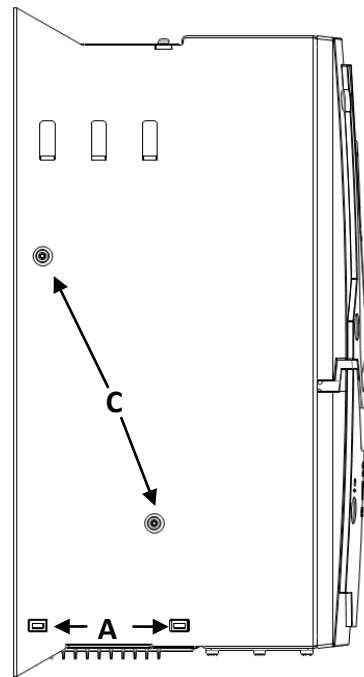
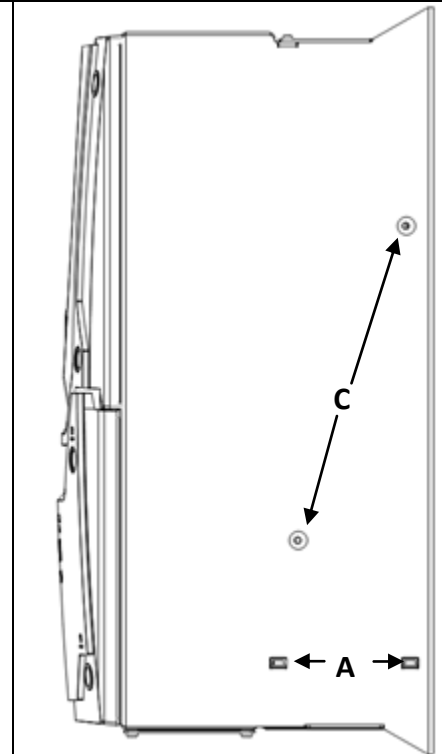
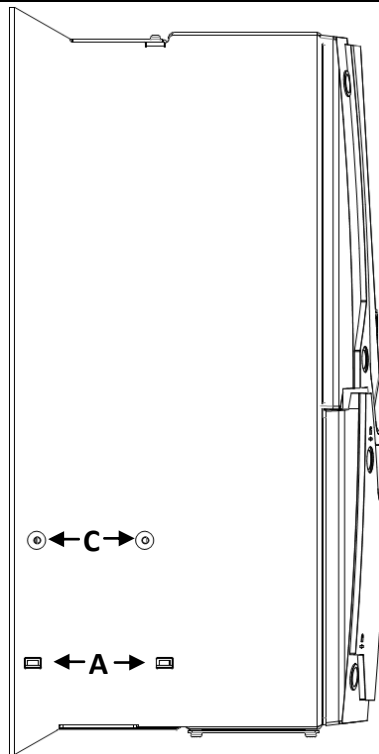
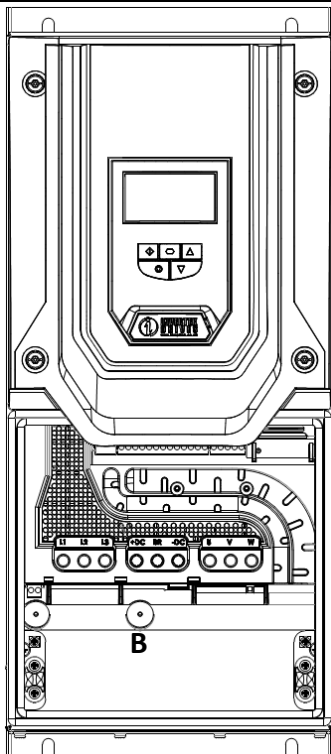

Figure 2



1. Remove the fan tray by pressing in the tabs “A” in figure 2 – two on each side of the drive.
2. Remove and retain the screws at locations C
3. Slide the resistor into the heatsink in the slot marked “B” in figure 1.
4. Refit the supplied retaining screws through holes marked “C” in figure 2. The screws should be tightened sufficiently to hold the resistor in place when the drive is mounted vertically
5. Refit the fan tray in its original position. The brake resistor connection cables should be passed through slot “B”, and then routed through the cable gland plate using a suitable gland or grommet to retain the ingress protection of the drive.

Mechanical Installation – Frame Size 5



1. Remove the fan tray by pressing the tabs marked “A”
2. Slide the resistor into the end channel of the heatsink. It is possible to mount one resistor on either side of the heatsink, allowing two resistors in parallel to be connected to the drive.
3. Pass the connection cables through the grommet marked “B” to allow connection to the drive terminals
4. Use the supplied mounting screws inserted through holes “C” to hold the resistor in place in the heatsink

Electrical Installation

The brake resistor connects to the terminals marked “+” or “DC+” and “BR”.
The brake resistor is activated as follows :-

Optidrive E2 (ODE-2-....)

1. Ensure you have access to the extended parameters by setting P-14 = 101 (default access code).
2. Set P-31 = 1 to enable the brake chopper with software protection suitable for the standard Invertek resistor.

Note

If using non-standard resistors (not supplied by Invertek), it is necessary to provide alternative means of protection against overload of the resistor, e.g. temperature monitoring or suitable thermal overload. Non-Invertek supplied resistors should not be mounted inside the drive.

Optidrive P2 (ODP-2-....)

Enable the brake circuit by setting P1-05 = 2.

Note

If using non-standard resistors (not supplied by Invertek), it is necessary to enter the correct data for the resistor into parameters as follows
Select Advanced Parameter Access by setting P1-14 = 201
Enter the resistance of the connected resistor into parameter P6-19
Enter the power rating of the connected resistor into P6-20
Non-Invertek supplied resistors should not be mounted inside the drive.